

Belt Scales



| | |
|------|--|
| | Milltronics Belt Scales |
| 4/2 | Introduction |
| 4/5 | Milltronics MLC |
| 4/9 | Milltronics MBS |
| 4/12 | Milltronics MUS |
| 4/16 | Milltronics MCS |
| 4/20 | Milltronics MSI and MMI |
| 4/29 | Milltronics WD600 |
| | Speed Sensors |
| 4/33 | Milltronics TASS |
| 4/35 | Milltronics RBSS |
| 4/38 | SITRANS WS100 |
| 4/43 | SITRANS WS300 |
| 4/48 | Milltronics Bend Pulleys |
| | Belt Scales Accessories |
| 4/52 | Milltronics MWL Weight Lifter |
| 4/57 | Milltronics Flat Bar Calibration Weights |
| 4/58 | Milltronics Test Chains |
| 4/62 | Milltronics Test Chain Storage Reels |
| 4/65 | Milltronics Belt Scale Peripherals |

Belt Scales

Milltronics Belt Scales

Introduction

Overview

Belt scales help maximize the use of raw materials, control inventories, and aid in the manufacturing of a consistent product. Milltronics belt scales from Siemens are easy to install, and require little maintenance. They produce repeatable, accurate results. These belt scales show minimal hysteresis and superior linearity, and ignore side loading. Load cell overload protection is a feature of the belt scale design. With use of approved intrinsically safe barrier strips, all belt scales can be used in hazardous locations.

Typical system

A typical belt scale system has a weigh bridge structure supported on load cells, an electronic integrator, and a belt speed sensor. The load cells measure the material weight on the belt, and send a signal to the integrator. The integrator also receives input in the form of electrical pulses from a belt speed sensor connected to a tail or bend pulley. Using these two sources of data, the integrator calculates the rate of material transferred along the belt using the equation $\text{weight} \times \text{speed} = \text{rate}$.

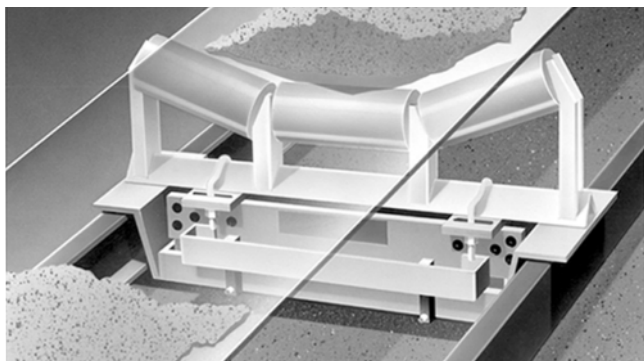

Belt scale operation

Mode of operation

Siemens Milltronics belt scales only measure the vertical component of the applied force. As material moves down the conveyor belt and travels over the belt scale, it exerts a force proportional to the material load through the suspended idler directly to the load cells. The resulting force applied in each load cell is sensed by its strain gauges. When the strain gauges are excited by voltage from the electronic integrator, they produce an electrical signal proportional to belt loading, which is then applied to the integrator.

The vertical movement of the load cells is limited by the positive overload stop incorporated into the design of the belt scale or load cells. The stops protect the load cells from failure in the event of extreme overload forces.

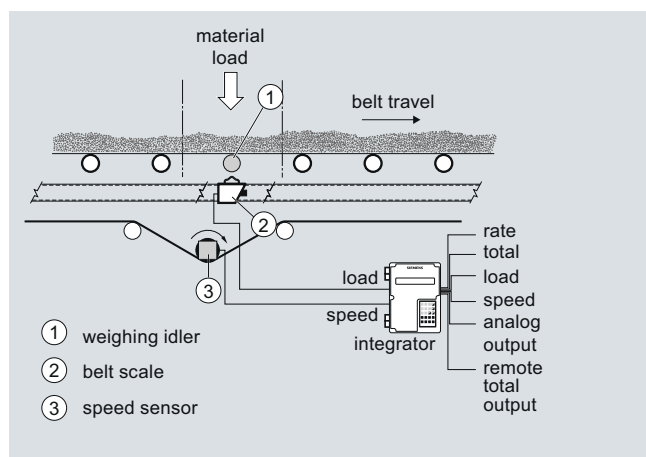

Installation tips

Position the scale

Locate the scale close to the tail section of the conveyor belt where tension is minimal and more consistent. Mount the scale on rigid mountings, away from equipment that may produce measurement disturbing vibrations. Avoid variable tension points, transition points, or slope change. The ideal location is a horizontal, even belt section, but you can achieve good results on slopes if the idlers are properly aligned. If the conveyor curves, locate the scale a proper distance from the tangent points of the curve. For concave curved conveyors, the recommended minimum distance is 12 m (40 ft) from the tangent points of the curve. With convex conveyors, the minimum distance is 6 m (20 ft) on the approach side, and 12 m (40 ft) on the retreat side. Be sure to install the scale a sufficient distance from the infeed section (at least one idler space) so the material has time to settle properly on the belt.

Reduce variable belt tension

With temperature variations, load, and other circumstances, the belt tension will change. To maintain proper tension, a gravity take-up is recommended. This is a weight designed to take up slack on the belt. A gravity take-up should move freely and place consistent tension on the belt. The use of screw take-ups should be limited to conveyors with pulley centers to 18.3 m (60 ft) or less. The amount of weight should conform to the conveyor design specifications.

Align the idlers

Precise idler alignment is essential. At least two idlers on each side of the scale should be aligned with the belt scale; use three or more for high accuracy applications. To check alignment, use wire, string, or fishing line across the top outer edges of the rollers and tighten enough to eliminate sag. Adjust the height of the rollers with shims until they are all even, or at least within ± 0.8 mm (1/32 inch). All of the scale-area idlers should be the same type (size, diameter, style, trough angle, and manufacture) and should be spaced at equal distances. Locate training idlers a minimum of 9 m (30 ft) from the belt scale idler.

Install speed sensors

The speed sensor should be attached to the tail pulley or bend pulley shaft so the connection does not slip. It is important that the speed sensor be properly mounted as described in the Operating Instructions and free of excessive vibration. Whenever possible, mount the speed sensor on a solid face pulley. The use of wing- or beater-type pulleys is not recommended.

Wheel driven speed sensors, that are applied to the return strand of the belt, should be located close to a return idler to ensure a stable drive surface.

Wire the scale

Follow good instrumentation wiring practices to protect the load cell and speed sensor signals from radio frequency interference and induction. Use terminal blocks, shielded cable, and grounded metal conduit for all wiring.

Mode of operation (continued)

SIEMENS

Belt Scale Application Questionnaire

Customer information

Contact: _____ Prepared By: _____
 Company: _____ Date: _____
 Address: _____ Notes on the Application: _____
 City: _____ Country: _____
 State/Province: _____ Zip/Postal Code: _____
 Phone: (_____) _____ Fax: (_____) _____ E-mail: _____

Material

Material being measured: _____ Particle size: _____ mm/Inch/mesh

Corrosive state of material: High Moderate Not corrosive

Conveyor

(Supply sketch where possible)

Sketch attached

Application: Inventory Load out Control Blending Legal for trade

Feed rate: _____ minimum t/hr or kg/hr or lb/hr or LTPH or STPH Accuracy required: +/- _____ %
 _____ maximum t/hr or kg/hr or lb/hr or LTPH or STPH Constant feed rate: Yes No

Electrical classification at scale location: _____

Profile: Horizontal Incline / Decline _____ Degrees Variable Incline _____ Degrees Curved

Belt speed: _____ minimum m/sec. or ft/min. Belt length: _____ m/ft.
 _____ maximum m/sec. or ft/min. Belt width: _____ mm/in.

Tail pulley diameter: _____ mm/in.

Idler diameter: _____ mm/in.

Trough angle: _____ Degrees

Idler spacing: _____ mm/in.

A = _____ mm/in.

Y = _____ mm/in.

W = _____ mm/in.

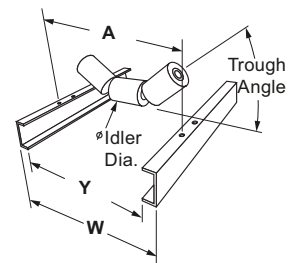

Integrator Requirements

(indicate all that apply)

Power available: _____

Inputs required:

- 4 ... 20 mA (specify) _____
- PID
- LVDT
- Load Cells (#): _____

Outputs required:

- 4 ... 20 mA _____
- PID
- Remote totalizer
- Relays (#): _____

Communications:

- AB Remote I/O
- DeviceNet
- PROFIBUS DP
- RS-232 / RS-485 Modbus

Products suggested:

Preferred Belt Scale Model: MBS MUS MCS MSI MMI MLC WD600

Preferred Construction: Painted mild steel 304 SS 316 SS Galvanized mild steel

Belt Scales

Milltronics Belt Scales

Introduction

Technical specifications

| Criteria | Typical industries | Typical applications | Maximum capacity | Maximum belt speed | Loading range | Accuracy ¹⁾ | | Approvals |
|------------------------|--|---|---|---------------------------|-------------------|---|-----------------------------|--|
| | | | | | | Value | Specified range | |
| Milltronics MLC | Animal feed, fertilizers, food processing, tobacco | Secondary industries | 50 t/h (55 STPH) at max. belt speed | 2.0 m/s (400 fpm) | Light | ± 0.5 ... 1 % | 25 ... 100 % | CE, C-TICK |
| Milltronics MBS | Aggregates, mining, animal feed | Aggregates, medium-duty | 1500 t/h (1650 STPH) at max. belt speed | 3.0 m/s (600 fpm) | Moderate | ± 1 % | 33 ... 100 % | CE, C-TICK |
| Milltronics MUS | Aggregates, agricultural, mining, cement | Aggregates, medium- to heavy-duty | 5000 t/h (5500 STPH) at max. belt speed | 3.0 m/s (600 fpm) | Light to heavy | ± 0.5 ... 1 % | 25 ... 100 % | CE, C-TICK |
| Milltronics MCS | Aggregates | Mobile crushers, aggregates, screening plants, heavy-duty | 2400 t/h (2640 STPH) at max. belt speed | 3.0 m/s (600 fpm) | Light to heavy | ± 0.5 ... 1 % | 25 ... 100 % | CE, CSA/FM, ATEX, IECEX, C-TICK |
| Milltronics MSI | Cement, chemicals, coal, food processing, mineral processing, mining | Industrial heavy-duty, SABS approval | 12000 t/h (13200 STPH) at max. belt speed | 5.0 m/s (984 fpm) | Moderate to heavy | ± 0.5 % or better | 20 ... 100 % | SABS, MID, OIML, Measurement Canada, CE, CSA/FM, ATEX, IECEX, C-TICK |
| Milltronics MMI | Cement, chemicals, coal, food processing, mineral processing, mining | Industrial heavy-duty, NTEP, Measurement Canada approval | 12000 t/h (13200 STPH) at max. belt speed | 5.0 m/s (984 fpm) | Moderate to heavy | MMI-2 (2 idler): ± 0.25 % or better MMI-3 (3 idler): ± 0.125 % or better | 20 ... 100 % 25 ... 10 % | NTEP, MID, OIML, Measurement Canada, CE, CSA/FM, ATEX, IECEX, C-TICK |
| WD600 | Food, pharmaceutical and tobacco industries | Process and load-out control Light- to medium-duty | Up to 100 t/h | 2.0 m/s (400 fpm) maximum | Light to moderate | ± 0.5 ... 1 % | 25 ... 100 % | CE, meets FDA/USDA requirements for food processors, C-TICK |

¹⁾ Accuracy subject to: On factory approved installations the belt scale system's totalized weight will be within the specified accuracy when compared to a known weighed material test sample. The test rate must be within the specified range of the design capacity and held constant for the duration of the test. The minimum material test sample must be equivalent to a sample obtained at the test flow rate for three revolutions of the belt or at least ten minutes running time, whichever is greater.

Overview

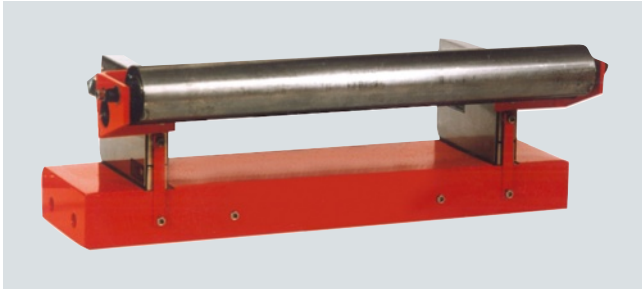

Milltronics MLC is a low-capacity scale for light belt loading.

Benefits

- Unique parallelogram style load cell design
- Designed for light product loading
- Compact and easy to install
- System includes weighing idler
- Stainless steel option
- Low cost of ownership

Application

The MLC is suitable for monitoring such products as fertilizer, tobacco, animal feed pellets, or sugar.

The MLC's patented use of parallelogram style load cells results in fast reaction to vertical forces, ensuring instant response to product loading. This enables it to provide outstanding accuracy and repeatability even with very light loading. The MLC may be easily installed in existing flat belt conveyors or belt feeders.

Operating with Milltronics BW100, BW500, or SIWAREX FTC microprocessor-based integrators, the MLC provides indication of flow rate, total weight, belt load and belt speed of bulk solids materials on a belt conveyor. A speed sensor monitors conveyor belt speed for input to the integrator. When used in conjunction with Milltronics BW500 integrator with PID controller, the MLC may also be used in the food industry as part of a pre-feed control system for extruders, cookers and de-hydrators.

Technical specifications

| Milltronics MLC | |
|----------------------------|---|
| Mode of operation | |
| Measuring principle | Strain gauge load cell measuring load on flat belt conveyor idler |
| Typical application | Monitor fertilizer, tobacco, animal feed pellets, sugar, cereal |
| Performance | |
| Accuracy ¹⁾ | ± 0.5 ... 1.0 % of totalization over 25 ... 100 % operating range |
| Medium conditions | |
| Max. material temperature | 85 °C (185 °F) |
| Belt design | |
| Belt width | <ul style="list-style-type: none"> • 450 ... 1200 mm • 18 ... 48 inch |
| Belt speed | 2.0 m/s (400 fpm) maximum ²⁾ |
| Capacity | Up to 50 t/h (55 STPH) |
| Conveyor incline | <ul style="list-style-type: none"> • ± 20° from horizontal, fixed incline • Up to ± 30° with reduced accuracy |
| Idlers | |
| Conveyor idler | Horizontal |
| Idler diameter | 50 or 60 mm (1.90 or 2.30 inch) |
| Idler spacing | 0.5 ... 1.5 m (1.6 ... 5.0 ft) |
| Load cell | |
| Construction | 17-4 PH (1.4568) stainless steel construction with 304 (1.4301) stainless steel cover |
| Degree of protection | IP67 |
| Excitation | 10 V DC nominal, 15 V DC maximum |
| Output | 2 mV/V excitation at rated load cell capacity |
| Non-linearity | 0.03 % of rated output |
| Hysteresis | 0.05 % of rated output |
| Non-repeatability | 0.03 % of rated output |
| Capacity | 10 or 20 lb |
| Overload | 150 % of rated capacity, ultimate 300 % of rated capacity |
| Temperature | <ul style="list-style-type: none"> • -40 ... +85 °C (-40 to +185 °F) operating range • -10 ... +60 °C (14 ... 140 °F) compensated |
| Mounting dimensions | Identical for all capacities |
| Hazardous locations | Consult the factory |
| Approvals | CE, C-TICK, GOST |

¹⁾ Accuracy subject to: On factory approved installations the belt scale system's totalized weight will be within the specified accuracy when compared to a known weighed material test sample. The test rate must be within the specified range of the design capacity and held constant for the duration of the test. The minimum material test sample must be equivalent to a sample obtained at the test flow rate for three revolutions of the belt or at least ten minutes running time, whichever is greater.

²⁾ Contact Siemens application engineering for consideration of higher belt speeds.

Belt Scales

Milltronics Belt Scales

Milltronics MLC

Selection and Ordering data

| | Order No. |
|--|-------------------------|
| Milltronics MLC Belt Scale Low-capacity scale for light belt loading that comes complete with a weighing idler. | C) 7MH7126- |
| Belt width/Scale construction <u>Polyester painted mild steel</u> | |
| 18 inch (457 mm) | 1 A |
| 24 inch (610 mm) | 1 B |
| 30 inch (762 mm) | 1 C |
| 36 inch (914 mm) | 1 D |
| 42 inch (1067 mm) | 1 E |
| 48 inch (1219 mm) | 1 F |
| 500 mm (20 inch) | 1 G |
| 650 mm (26 inch) | 1 H |
| 800 mm (32 inch) | 1 J |
| 1000 mm (39 inch) | 1 K |
| 1200 mm (47 inch) | 1 L |
| 450 mm (18 inch) | 1 M |
| <u>Stainless steel 304 (1.4301)</u> | |
| 18 inch (457 mm) | 2 A |
| 24 inch (610 mm) | 2 B |
| 30 inch (762 mm) | 2 C |
| 36 inch (914 mm) | 2 D |
| 42 inch (1067 mm) | 2 E |
| 48 inch (1219 mm) | 2 F |
| 500 mm (20 inch) | 2 G |
| 650 mm (26 inch) | 2 H |
| 800 mm (32 inch) | 2 J |
| 1000 mm (39 inch) | 2 K |
| 1200 mm (47 inch) | 2 L |
| 450 mm (18 inch) | 2 M |
| Load cell capacity | |
| 10 lb (4.55 kg) | A |
| 20 lb (9.09 kg) | B |
| Not specified ¹⁾ | X |
| Weighing idler dimensions | |
| 50 mm (1.96 inch) ²⁾ | 1 |
| 60 mm (2.40 inch) ³⁾ | 2 |
| 1.90 inch (48.2 mm) ⁴⁾ | 5 |
| Further designs | Order Code |
| Pls. add "-Z" to Order No. and specify Order code(s). | |
| Stainless Steel tag [69 x 38 mm (2.7 x 1.5 inch)], Measuring-point number / identification (max 16 characters), specify in plain text. | Y15 |
| Manufacturer's Test Certificate: According to EN 10204-2.2 | C11 |
| Operating Instructions | Order No. |
| • English | C) 7ML1998-5FF01 |
| • German | C) 7ML1998-5FF31 |
| Belt Scale Application Guidelines | |
| • English | C) 7ML1998-5GA01 |
| • French | C) 7ML1998-5GA11 |
| • German | C) 7ML1998-5GA31 |
| • Spanish | C) 7ML1998-5GA21 |

| | Order No. |
|--|--------------------|
| Milltronics MLC Belt Scale Low-capacity scale for light belt loading that comes complete with a weighing idler. | C) 7MH7126- |
| Note: The Operating Instructions should be ordered as a separate item on the order. | |
| This device is shipped with the Siemens Milltronics manual CD containing the complete Operating Instructions library. | |
| Spare parts | |
| Load cell, 10 lb (4.55 kg), 17-4 PH (1.4568) stainless steel construction with 304 (1.4301) stainless steel cover, includes hardware | 7MH7725-1AA |
| Load cell, 20 lb (9.09 kg), 17-4 PH (1.4568) stainless steel construction with 304 (1.4301) stainless steel cover, includes hardware | 7MH7725-1AB |
| Conduit replacement kit | 7MH7723-1NA |
| Milltronics MLC calibration weight [Stainless Steel 304 (1.4301)] | |
| <u>For scales with belt width of 18 inch or 450 mm</u> | |
| 1.05 lb (0.47 kg) | 7MH7724-1AL |
| 1.63 lb (0.73 kg) | 7MH7724-1AM |
| 2.35 lb (1.06 kg) | 7MH7724-1AN |
| 3.21 lb (1.45 kg) | 7MH7724-1AP |
| <u>For scales with belt width of 24 inch or 650 mm</u> | |
| 1.38 lb (0.62 kg) | 7MH7724-1AQ |
| 2.15 lb (0.97 kg) | 7MH7724-1AR |
| 3.11 lb (1.41 kg) | 7MH7724-1AS |
| 4.24 lb (1.91 kg) | 7MH7724-1AT |
| <u>For scales with belt width of 30 inch or 800 mm</u> | |
| 1.72 lb (0.77 kg) | 7MH7724-1AU |
| 2.67 lb (1.21 kg) | 7MH7724-1AV |
| 3.85 lb (1.73 kg) | 7MH7724-1AW |
| 5.26 lb (2.37 kg) | 7MH7724-1AX |
| <u>For scales with belt width of 36 inch or 1000 mm</u> | |
| 2.05 lb (0.92 kg) | 7MH7724-1AY |
| 3.19 lb (1.44 kg) | 7MH7724-1BA |
| 4.56 lb (2.07 kg) | 7MH7724-1BB |
| 6.29 lb (2.83 kg) | 7MH7724-1BC |
| <u>For scales with belt width of 42 inch or 1000 mm</u> | |
| 2.38 lb (1.07 kg) | 7MH7724-1BD |
| 3.71 lb (1.67 kg) | 7MH7724-1BE |
| 5.35 lb (2.41 kg) | 7MH7724-1BF |
| 7.31 lb (3.29 kg) | 7MH7724-1BG |
| <u>For scales with belt width of 48 inch or 1200 mm</u> | |
| 2.72 lb (1.22 kg) | 7MH7724-1BH |
| 4.23 lb (1.92 kg) | 7MH7724-1BJ |
| 6.06 lb (2.75 kg) | 7MH7724-1BK |
| 8.34 lb (3.75 kg) | 7MH7724-1BL |

1) Only for quotation purposes, not a valid ordering option.

2) Available with Belt width/Scale construction options 1G to 1M and 2G to 2M only

3) Available with Belt width/Scale construction options 1G to 1M only

4) Available with Belt width/Scale construction options 1A to 1F and 2A to 2F only

C) Subject to export regulations AL: N, ECCN: EAR99.

Dimensional drawings

Installation

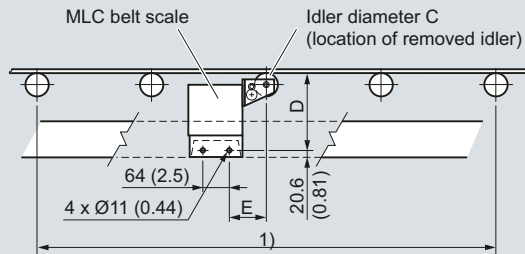

Plan View

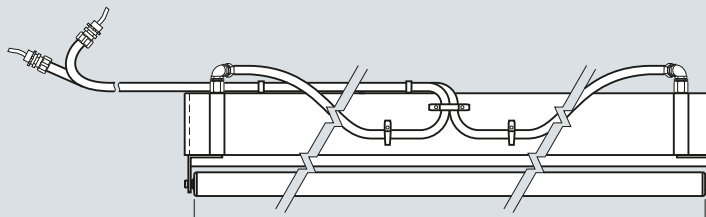

Front View

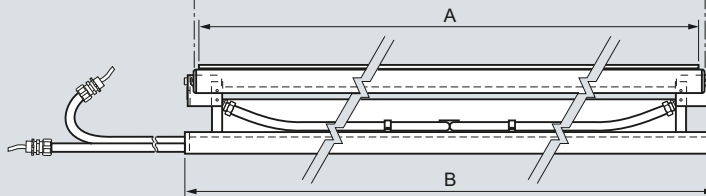

1) For pan supported belts, the belt should be cut out to allow the MLC and at least two (preferably four) other idlers to be installed.

Imperial designs [dimensions in inch (mm)]

| Scale size | 'A' roller width | 'B' dimension | 'C' dimension | 'D' dimension | 'E' dimension |
|------------|------------------|---------------|---------------|---------------|---------------|
| 18 (457) | 18 (457) | 19 (483) | 1.90 (48.3) | 6.19 (157) | 3.5 (89) |
| 24 (610) | 24 (610) | 25 (635) | 1.90 (48.3) | 6.19 (157) | 3.5 (89) |
| 30 (762) | 30 (762) | 31 (787) | 1.90 (48.3) | 6.19 (157) | 3.5 (89) |
| 36 (914) | 36 (914) | 37 (940) | 1.90 (48.3) | 6.19 (157) | 3.5 (89) |
| 42 (1067) | 42 (1067) | 43 (1092) | 1.90 (48.3) | 6.19 (157) | 3.5 (89) |
| 48 (1219) | 48 (1219) | 49 (1245) | 1.90 (48.3) | 6.19 (157) | 3.5 (89) |

Metric designs [dimensions in mm (inch)]

| Scale size | 'A' roller width | 'B' dimension | 'C' dimension | 'D' dimension | 'E' dimension |
|--------------|------------------|---------------|---------------|---------------|---------------|
| 450 (17.72) | 450 (17.72) | 500 (19.69) | 50 (1.97) | 158 (6.22) | 96 (3.78) |
| 500 (19.69) | 500 (19.69) | 550 (21.65) | 50 (1.97) | 158 (6.22) | 96 (3.78) |
| 650 (25.59) | 650 (25.59) | 700 (27.56) | 50 (1.97) | 158 (6.22) | 96 (3.78) |
| 800 (31.50) | 800 (31.50) | 850 (33.46) | 50 (1.97) | 158 (6.22) | 96 (3.78) |
| 1000 (39.37) | 1000 (39.37) | 1050 (41.34) | 60 (2.36) | 158 (6.22) | 96 (3.78) |
| 1200 (47.24) | 1200 (47.24) | 1250 (49.21) | 60 (2.36) | 158 (6.22) | 96 (3.78) |

Milltronics MLC, dimensions in inch (mm) respectively in mm (inch)

Belt Scales

Milltronics Belt Scales

Milltronics MLC

Schematics

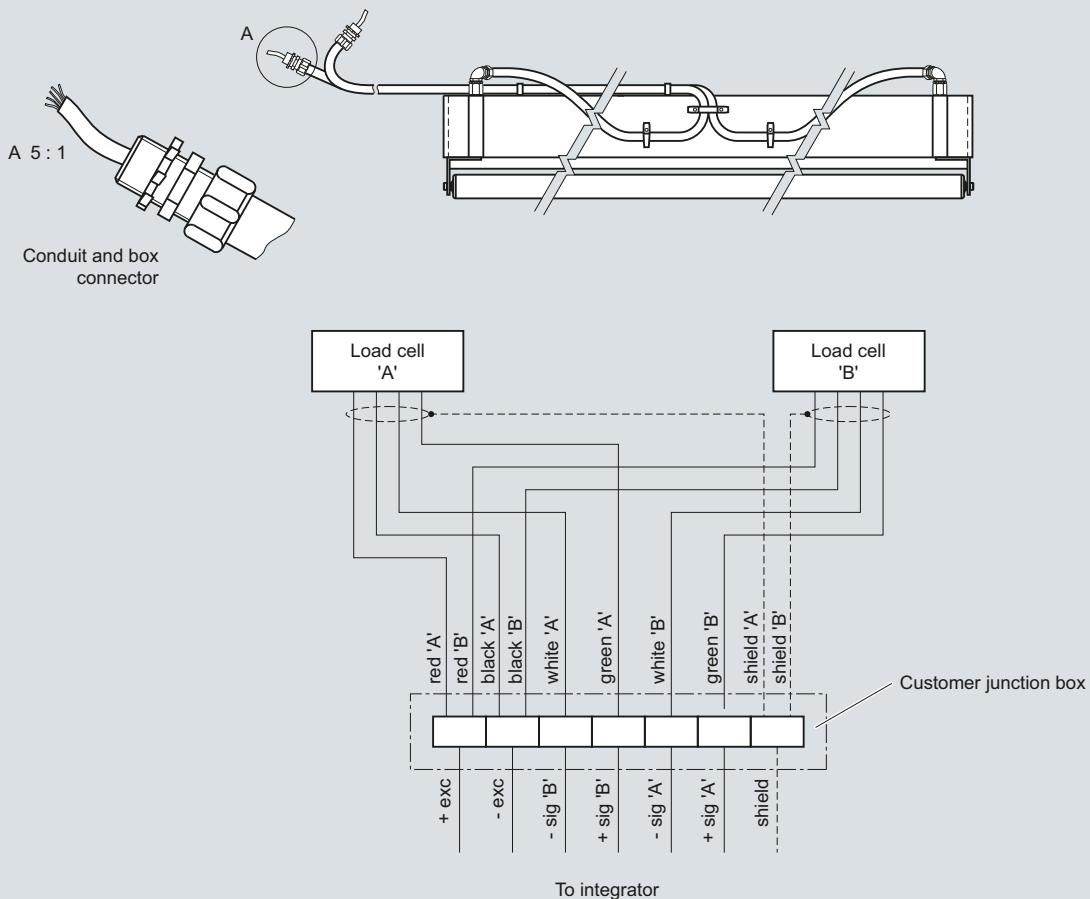

Note:
Conduit and cable arrangement may differ from example shown.

MLC connections

4

Belt Scales

Milltronics Belt Scales

Milltronics MBS

Overview

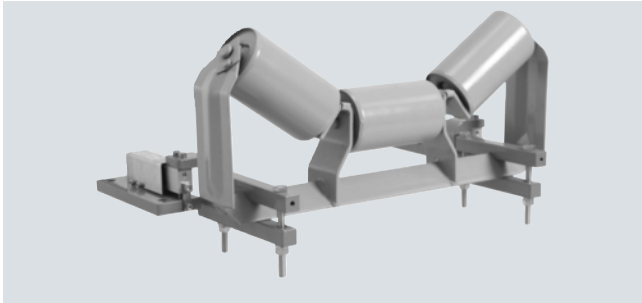

Milltronics MBS is a basic, modular, medium-duty belt scale providing dynamic weighing information for process indication. Idler not included with belt scale.

Benefits

- Unique modular design
- Simple installation
- Low cost
- Easy retrofit

Application

Milltronics MBS is used with aggregates, sand, or minerals, animal feeds or grains, providing basic continuous in-line weighing at a minimal cost. With no cross bridge, this versatile unit will fit most conveyor widths and standard idlers, and product buildup is reduced.

The construction and easy assembly of the MBS ensure quick delivery to meet even the tightest of schedules. Where scales are moved from conveyor to conveyor, the MBS also provides unmatched flexibility.

Operating with Milltronics BW100, BW500, or SIWAREX FTC microprocessor-based integrators, the MBS provides indication of flow rate, total weight, belt load, and speed of bulk solids materials on a belt conveyor. A speed sensor monitors conveyor belt speed for input to the integrator.

Technical specifications

Milltronics MBS

Mode of operation

| | |
|----------------------|---|
| Measuring principle | Heavy duty strain gauge load cells measuring load on belt conveyor idlers |
| Typical applications | <ul style="list-style-type: none"> • Monitor feed rates of fractionated stone, sand, animal feeds, grains • Track daily production totals |

Performance

| | |
|------------------------|--|
| Accuracy ¹⁾ | ± 1 % of totalization over 33 ... 100 % operating range, application dependent |
|------------------------|--|

Medium conditions

| | |
|---------------------------|----------------|
| Max. material temperature | 70 °C (158 °F) |
|---------------------------|----------------|

Belt design

| | |
|------------|---|
| Belt width | <ul style="list-style-type: none"> • Standard duty up to 1000 mm (CEMA width up to 42 inch) • Refer to dimensional drawings section |
| Belt speed | Up to 3.0 m/s (600 fpm) ²⁾ |

| | |
|----------|--|
| Capacity | Up to 1500 t/h (1650 STPH) at maximum belt speed |
|----------|--|

| | |
|---|---|
| Conveyor incline | <ul style="list-style-type: none"> • ± 20° from horizontal, fixed incline • Up to ± 30° with reduced accuracy³⁾ |
| Idlers | |
| Idler profile | <ul style="list-style-type: none"> • Flat to 35° • To 45° with reduced accuracy³⁾ 50 ... 150 mm (2 ... 6 inch) |
| Idler diameter | 50 ... 150 mm (2 ... 6 inch) |
| Idler spacing | 0.6 ... 1.5 m (2.0 ... 5.0 ft) |
| Load cell | |
| Construction | Aluminum |
| Degree of protection | IP66 |
| Excitation | 10 V DC nominal, 15 V DC max. |
| Output | 2 ± 0.02 mV/V excitation at rated load cell capacity |
| Non-repeatability | 0.01 % of rated output |
| Non-linearity | 0.02 % of rated output |
| Hysteresis | 0.02 % of rated output |
| Capacity | 30, 50, 100 kg (66, 110, 220 lb) |
| Overload | 150 % of rated capacity, ultimate 200 % of rated capacity |
| Temperature | <ul style="list-style-type: none"> • -30 ... +70 °C (-22 ... +158 °F) operating range • -10 ... +40 °C (15 ... 105 °F) compensated |
| Weight | 12 kg (26 lb), 6 kg (13 lb) per side |
| Interconnection wiring (to integrator) | <ul style="list-style-type: none"> • < 150 m (500 ft) 18 AWG (0.75 mm²) 6 conductor shielded cable • > 150 ... 300 m (500 ... 1000 ft) 18 ... 22 AWG (0.75 ... 0.34 mm²) 8 conductor shielded cable |
| Hazardous locations | Consult the factory |
| Approvals | CE, C-TICK |

¹⁾ Accuracy subject to: On factory approved installations the belt scale system's totalized weight will be within the specified accuracy when compared to a known weighed material test sample. The test rate must be within the specified range of the design capacity and held constant for the duration of the test. The minimum material test sample must be equivalent to a sample obtained at the test flow rate for three revolutions of the belt or at least ten minutes running time, whichever is greater.

²⁾ Contact Siemens application engineering for consideration of higher belt speeds.

³⁾ Review by Siemens application engineer required.

Belt Scales

Milltronics Belt Scales

Milltronics MBS

| Selection and Ordering data | Order No. |
|---|--|
| Milltronics MBS Belt Scale A basic, modular, medium-duty belt scale providing dynamic weighing information for process indication. | C) 7MH7121-  |
| Scale construction Standard [up to 1000 mm (42 inch) belt width] | 1 |
| Load cell capacity 30 kg (66 lb) 50 kg (110 lb) 100 kg (220 lb) Not specified ¹⁾ | AB AC AE XX |
| Fabrication Polyester painted mild steel Polyester painted mild steel, for use with flat bar calibration | 1 2 |
| Further designs Please add "-Z" to Order No. and specify Order code(s). Stainless Steel tag [69 x 38 mm (2.7 x 1.5 inch)], Measuring-point number / identification (max 16 characters), specify in plain text. Manufacturer's Test Certificate: According to EN 10204-2.2 | Order Code Y15 C11 |
| Operating Instructions <ul style="list-style-type: none"> English French German Belt Scale Application Guidelines <ul style="list-style-type: none"> English French German Spanish Note: The Operating Instructions and application guidelines manual should be ordered as separate lines on the order. This device is shipped with the Siemens Milltronics manual CD containing the complete Operating Instructions library. | Order No. C) 7ML1998-5JN01 C) 7ML1998-5JN11 C) 7ML1998-5JN31 C) 7ML1998-5GA01 C) 7ML1998-5GA11 C) 7ML1998-5GA31 C) 7ML1998-5GA21 |
| Spare parts Load cell, 30 kg (66 lb), aluminum Load cell, 50 kg (110 lb), aluminum Load cell, 100 kg (220 lb), aluminum Conduit replacement kit | C) 7MH7725-1BK C) 7MH7725-1BL C) 7MH7725-1BM 7MH7723-1NA |
| Calibration Weights Flat bar/MWL retrofit kit Calibration test arm assembly, c/w one 8.2 kg (18 lb) calibration weight Calibration test arm assembly, c/w two 8.2 kg (18 lb) calibration weights MBS/MCS calibration arm c/w idler clip (holds up to two 8.2 kg (18 lb) weights) Calibration weight, 8.2 kg (18 lb) 6.0 lb (2.7 kg) Milltronics flat bar calibration weights, see page 4/57 Note: The calibration arm and weights should be ordered as separate lines on the order. | C) 7MH7723-1HA 7MH7723-1FR 7MH7723-1FS 7MH7726-1AD 7MH7724-1AA 7MH7724-1AB |

¹⁾ Only for quotation purposes, not a valid ordering option.

C) Subject to export regulations AL: N, ECCN: EAR99.

Dimensional drawings

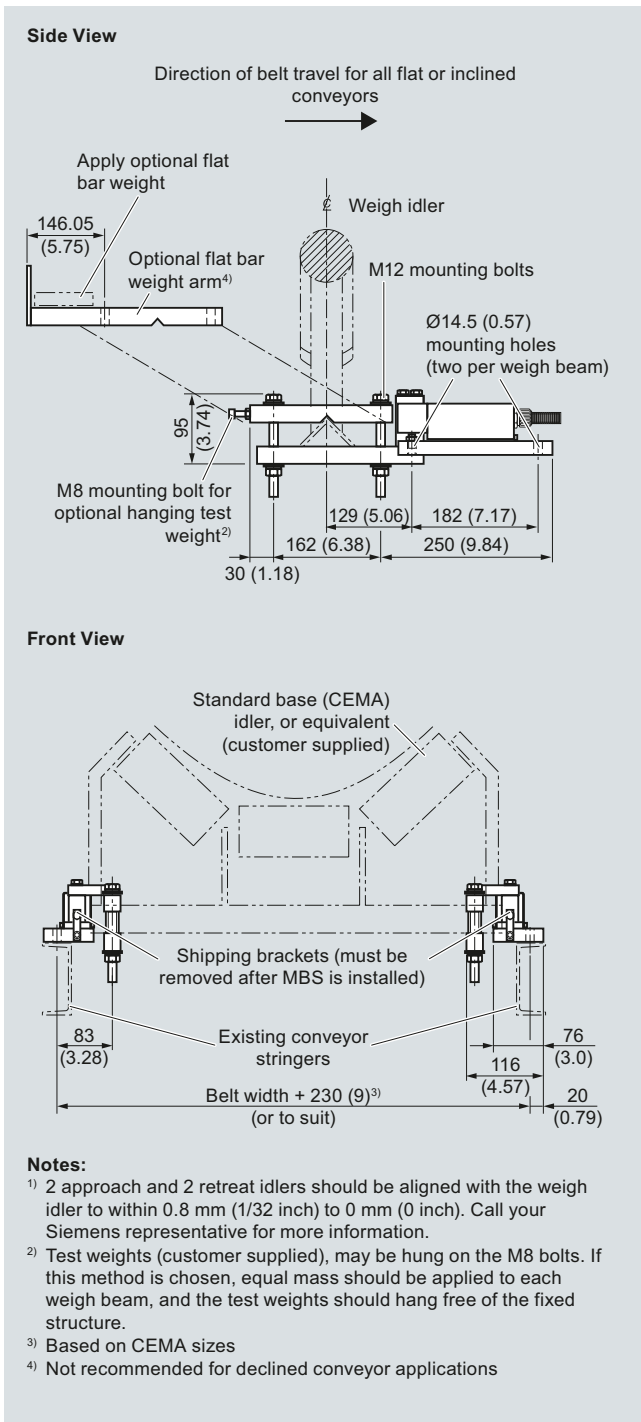

MBS dimensions in mm (inch)

Schematics

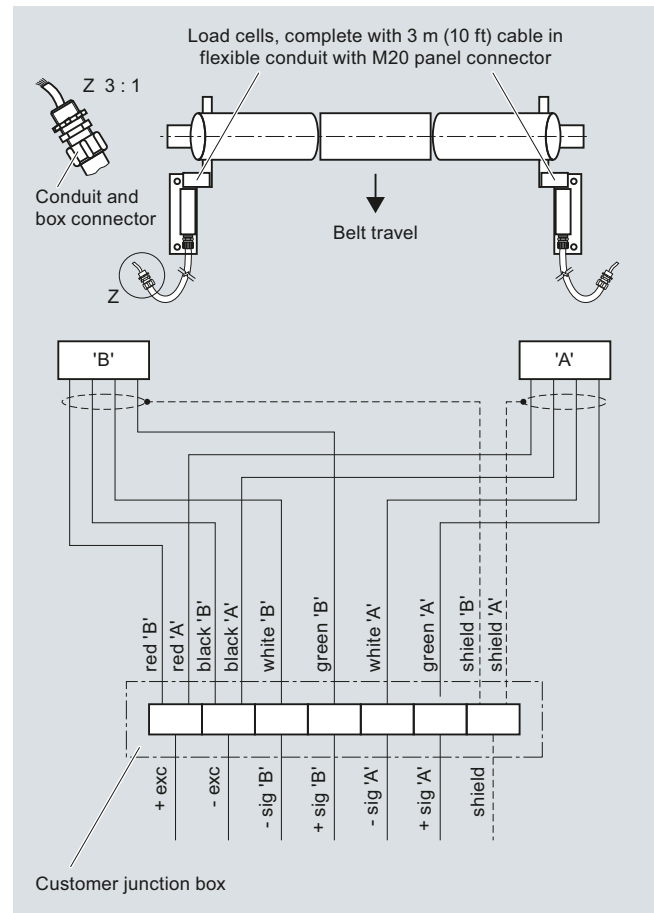

MBS connections

Belt Scales

Milltronics Belt Scales

Milltronics MUS

Overview



Milltronics MUS is a modular designed, medium- to heavy-duty belt scale for process indication. Idler not included with belt scale.

Benefits

- Unique modular design
- Simple installation
- Low cost
- Easy retrofit

Application

Milltronics MUS operates with products like aggregates, sand, or minerals, providing continuous in-line weighing at a minimal cost. With no cross bridge, this versatile unit will fit most conveyor widths and standard idlers, and product build-up is reduced.

The construction and easy assembly of the MUS ensures quick delivery to meet even the tightest of schedules. Where scales are moved from conveyor to conveyor, the MUS also provides unmatched flexibility.

Operating with Milltronics BW100, BW500, or SIWAREX FTC microprocessor-based integrators, the MUS provides indication of flow rate, total weight, belt load, and speed of bulk solids materials on a belt conveyor. A speed sensor monitors conveyor belt speed for input to the integrator.

Technical specifications

Milltronics MUS

Mode of operation

| | |
|----------------------|--|
| Measuring principle | Heavy duty strain gauge load cells measuring load on belt conveyor idlers |
| Typical applications | <ul style="list-style-type: none"> • Monitor fractionated stone on secondary surge belts and recirculating loads • Track daily production totals |

Measurement accuracy

| | |
|------------------------|--|
| Accuracy ¹⁾ | ± 0.5 ... 1 % of totalization over 25 ... 100 % operating range, application dependent |
|------------------------|--|

Medium conditions

| | |
|---------------------------|----------------|
| Max. material temperature | 65 °C (150 °F) |
|---------------------------|----------------|

Belt design

| | |
|------------|--|
| Belt width | <ul style="list-style-type: none"> • Standard duty up to 1000 mm (CEMA width up to 42 inch) • Heavy-duty up to 1524 mm (CEMA width up to 60 inch) • Refer to dimensional drawings section |
|------------|--|

| | |
|------------|---------------------------------------|
| Belt speed | Up to 3.0 m/s (600 fpm) ²⁾ |
|------------|---------------------------------------|

Capacity

| | |
|----------|--------------------------------------|
| Capacity | Up to 5000 t/h at maximum belt speed |
|----------|--------------------------------------|

Conveyor incline

| | |
|------------------|--|
| Conveyor incline | <ul style="list-style-type: none"> • ± 20° from horizontal, fixed incline • Up to ± 30° with reduced accuracy³⁾ |
|------------------|--|

Idlers

| | |
|----------------|--|
| Idler profile | <ul style="list-style-type: none"> • Flat to 35° • To 45° with reduced accuracy³⁾ |
| Idler diameter | 50 ... 180 mm (2 ... 7 inch) |
| Idler spacing | 0.6 ... 1.5 m (2.0 ... 5.0 ft) |

Load cell

| | |
|------------------------------|---|
| Construction | Nickel plated alloy steel |
| Degree of protection | IP66 |
| Excitation | 10 V DC nominal, 15 V DC max. |
| Output | 2 mV/V excitation at rated load cell capacity |
| Non-linearity and hysteresis | 0.02 % of rated output |
| Non-repeatability | 0.01 % of rated output |

Capacity

| | |
|-------------|---|
| Capacity | <ul style="list-style-type: none"> • Standard duty ranges 20, 30, 50, 75, 100 kg (44, 66, 110, 165, 220 lb) • Heavy-duty ranges 50, 100, 150, 200, 500 kg (110, 220, 330, 440, 1100 lb) |
| Overload | 150 % of rated capacity, ultimate 200 % of rated capacity |
| Temperature | <ul style="list-style-type: none"> • -40 ... +65 °C (-40 ... +150 °F) operating range • -10 ... +40 °C (15 ... 105 °F) compensated |

Weight

| | |
|--------|---|
| Weight | Standard duty up to 44 lb (20 kg), 22 lb (10 kg) per side Heavy-duty up to 64 lb (30 kg), 32 lb (15 kg) per side |
|--------|---|

Interconnection wiring (to integrator)

| | |
|--|---|
| Interconnection wiring (to integrator) | <ul style="list-style-type: none"> • < 150 m (500 ft) 18 AWG (0.75 mm²) 6 conductor shielded cable • > 150 m ... 300 m (500 ... 1000 ft) 18 ... 22 AWG (0.75 ... 0.34 mm²) 8 conductor shielded cable |
|--|---|

Hazardous locations

| | |
|---------------------|---------------------|
| Hazardous locations | Consult the factory |
|---------------------|---------------------|

Approvals

| | |
|-----------|-----------------------|
| Approvals | CE, C-TICK, GOST, CMC |
|-----------|-----------------------|

¹⁾ Accuracy subject to: On factory approved installations the belt scale system's totalized weight will be within the specified accuracy when compared to a known weighed material test sample. The test rate must be within the specified range of the design capacity and held constant for the duration of the test. The minimum material test sample must be equivalent to a sample obtained at the test flow rate for three revolutions of the belt or at least ten minutes running time, whichever is greater.

²⁾ Contact Siemens application engineering for consideration of higher belt speeds.

³⁾ Review by Siemens application engineer required.

| Selection and Ordering data | Order No. | Order No. |
|---|--|--|
| Milltronics MUS Belt Scale Modular design, medium- to heavy-duty scale for process indication. Flat bar calibration weights are optional and should be ordered as separate items. | C) 7MH7123-0 | C) 7MH7123-0 |
| Scale construction Standard for belt width up to 1000 mm (42 inch), nickel plated steel load cells Heavy-duty for belt width up to 1524 mm (60 inch), nickel plated steel load cells | 1 2 | |
| Load cell capacity <u>Standard Duty Scale Load Cell</u> 20 kg (44.1 lb) ¹⁾ 30 kg (66.1 lb) ¹⁾ 50 kg (110.2 lb) ¹⁾ 75 kg (165.3 lb) ¹⁾ 100 kg (220.4 lb) ¹⁾ Not specified ²⁾ <u>Heavy-Duty Scale Load Cell</u> 50 kg (110.2 lb) ³⁾ 100 kg (220.4 lb) ³⁾ 150 kg (330.7 lb) ³⁾ 200 kg (440.9 lb) ³⁾ 300 kg (661.4 lb) ³⁾ 500 kg (1102.3 lb) ³⁾ | AA AB AC AD AE XX BA BB BC BD BE BF | |
| Fabrication Polyester painted mild steel | 1 | |
| Further designs Please add "-Z" to Order No. and specify Order code(s). Stainless Steel tag [69 x 38 mm (2.7 x 1.5 inch)], Measuring-point number / identification (max. 16 characters), specify in plain text. Manufacturer's Test Certificate: According to EN 10204-2.2 | Order Code Y15 C11 | |
| Milltronics MUS Belt Scale Modular design, medium- to heavy-duty scale for process indication. Flat bar calibration weights are optional and should be ordered as separate items. | | C) 7MH7123-0 |
| Operating Instructions <ul style="list-style-type: none"> English French Spanish German Dutch Additional Operating Instructions <u>Belt Scale Application Guidelines</u> <ul style="list-style-type: none"> English French Spanish German Note: The Operating Instructions and application guidelines manual should be ordered as separate items on the order. This device is shipped with the Siemens Milltronics manual CD containing the complete Operating Instructions library. | | C) 7ML1998-5CQ02 C) 7ML1998-1CQ11 C) 7ML1998-1CQ21 C) 7ML1998-5CQ31 C) 7ML1998-1CQ41 C) 7ML1998-5GA01 C) 7ML1998-5GA11 C) 7ML1998-5GA21 C) 7ML1998-5GA31 |
| Spare parts <u>Standard Duty Scale Load Cell</u> 20 kg (44.1 lb) 30 kg (66.1 lb) 50 kg (110.2 lb) 75 kg (165.3) 100 kg (220.5 lb) <u>Heavy-Duty Scale Load Cell</u> 50 kg (110.2 lb) 100 kg (220.5 lb) 150 kg (330.7 lb) 200 kg (440.9 lb) 300 kg (661.4 lb) 500 kg (1120.3 lb) Rock Guard, MUS Standard Duty Scale, spare Conduit replacement kit | | 7MH7725-1CP 7MH7725-1CQ 7MH7725-1CR 7MH7725-1CS 7MH7725-1CT 7MH7725-1CU 7MH7725-1CV 7MH7725-1CW 7MH7725-1CX 7MH7725-1CY 7MH7725-1DA C) 7MH7723-1DM C) 7MH7723-1NA |
| Calibration Weights Milltronics flat bar calibration weights, see page 4/57 | | |

1) For use with scale construction option 1 only

2) Only for quotation purposes, not a valid ordering option.

3) For use with scale construction option 2 only

C) Subject to export regulations AL: N, ECCN: EAR99.

Belt Scales

Milltronics Belt Scales

Milltronics MUS

Dimensional drawings

4

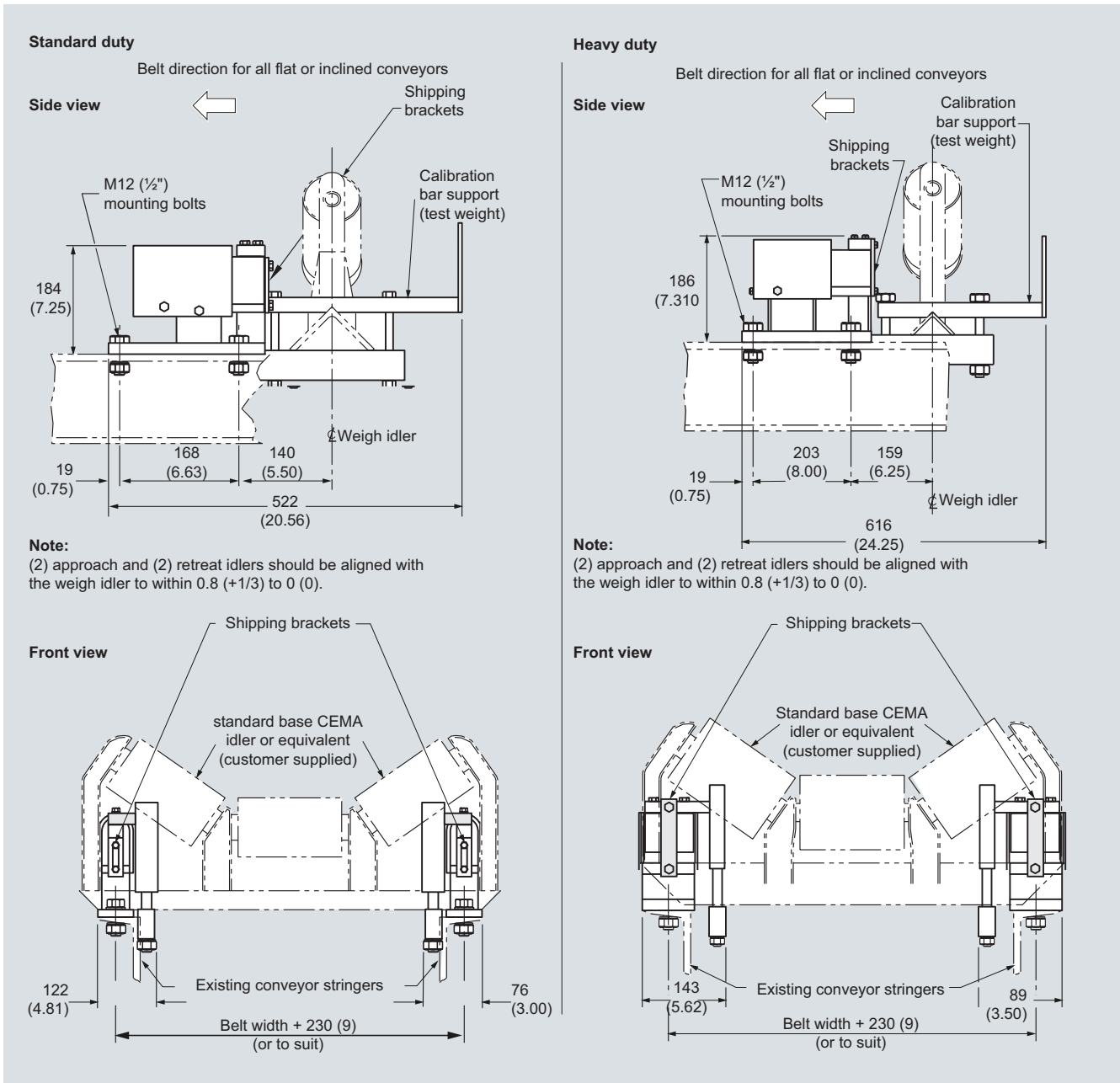

MUS dimensions in mm (inch)

Schematics

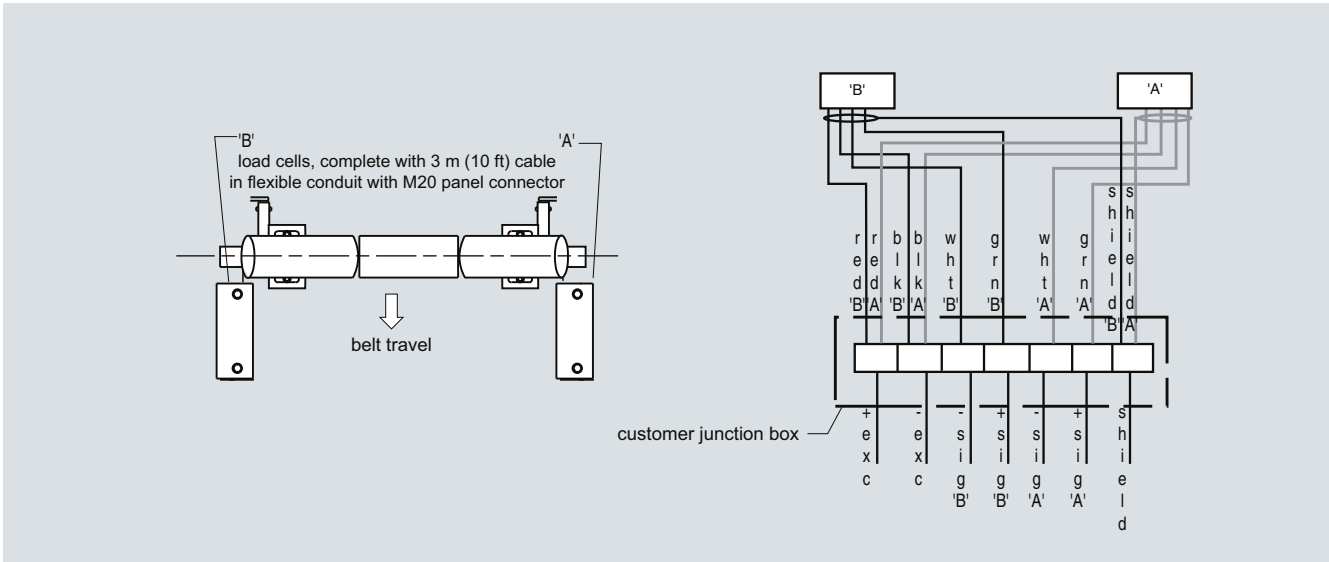

MUS connections

Belt Scales

Milltronics Belt Scales

Milltronics MCS

Overview

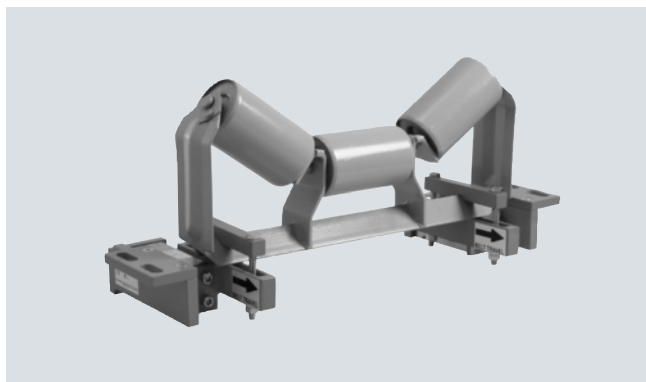

Milltronics MCS is a compact, rugged, modular, heavy-duty belt scale for use in mobile crushers and aggregate screening plants. Idler not included with belt scale.

Benefits

- Rugged design
- Low profile
- Easy retrofit
- Low cost
- Stainless steel load cells

Application

Milltronics MCS provides continuous, in-line weighing at minimal cost. The stainless steel load cells ensure long-term, consistent, reliable measurement. The modular construction and easy assembly of the MCS ensures quick delivery to meet even the tightest of schedules.

Operating with Milltronics BW100, BW500, or SIWAREX FTC microprocessor-based integrators, the MCS provides indication of flow rate, total weight, belt load, and belt speed of bulk solids materials on a belt conveyor.

To complete the weighing system, include a speed sensor to monitor conveyor belt speed for input to the integrator. On mobile crushing equipment, the TASS speed sensor is a compact, rugged speed sensor designed for use with the MCS.

Technical specifications

Milltronics MCS

Mode of operation

Measuring principle Strain gauge load cells measuring load on belt conveyor idlers

Typical application Mobile crusher systems

Measurement accuracy

Accuracy¹⁾

- $\pm 0.5 \dots 1$ % of totalization over 25 ... 100 % operating range, application dependent
- ± 2 % of totalization over 25 ... 100 % operating range on mobile crusher applications

Belt design

Belt width

- Up to 1600 mm (60 inch CEMA) width
- Refer to the dimensional drawings section

Belt speed Up to 4 m/s (800 fpm)²⁾

Capacity Up to 2400 t/h (2640 STPH) at maximum belt speed

| | |
|---|--|
| Conveyor incline | <ul style="list-style-type: none"> • $\pm 20^\circ$ from horizontal, fixed incline • Up to $\pm 30^\circ$ with reduced accuracy³⁾ |
| Idlers | |
| Idler profile | <ul style="list-style-type: none"> • Flat to 35° • To 45° with reduced accuracy³⁾ |
| Idler diameter | 100 ... 150 mm (4 ... 6 inch) |
| Idler spacing | 0.6 ... 1.2 m (2.0 ... 4.0 ft) |
| Load cell | |
| Construction | 17-4 PH (1.4568) stainless steel construction with 304 (1.4301) stainless steel cover |
| Degree of protection | IP67 |
| Excitation | 10 V DC nominal, 15 V maximum |
| Output | 2 mV/V excitation at rated load cell capacity |
| Non-linearity and hysteresis | 0.02 % of rated output |
| Non-repeatability | 0.01 % of rated output |
| Capacity | 25, 50, 100, 250, 500 lb stainless steel |
| Overload | 150 % of rated capacity, ultimate 300 % of rated capacity |
| Temperature | <ul style="list-style-type: none"> • $-40 \dots +75^\circ\text{C}$ ($-40 \dots +167^\circ\text{F}$) operating range • $-18 \dots +65^\circ\text{C}$ ($0 \dots 150^\circ\text{F}$) compensated |
| Weight | Up to 20 kg (44 lb), 10 kg (22 lb) per side |
| Interconnection wiring (to integrator) | <ul style="list-style-type: none"> • < 150 m (500 ft) 18 AWG (0.75 mm^2) 6 conductor shielded cable • > 150 m (500 ft) to 300 m (1000 ft) 18 ... 22 AWG ($0.75 \dots 0.34 \text{ mm}^2$), 8 conductor shielded cable |
| Approvals | <ul style="list-style-type: none"> • CSA/FM Class II, Div. 1, Groups E,F,G and Class III • ATEX II 2D, Ex tD A21 IP65 T90 °C • IECEx Ex tD A21 IP65 T90 °C • CE, C-TICK, GOST |

¹⁾ Accuracy subject to: On factory approved installations the belt scale system's totalized weight will be within the specified accuracy when compared to a known weighed material test sample. The test rate must be within the specified range of the design capacity and held constant for the duration of the test. The minimum material test sample must be equivalent to a sample obtained at the test flow rate for three revolutions of the belt or at least ten minutes running time, whichever is greater.

²⁾ Contact Siemens application engineering for consideration of higher belt speeds

³⁾ Review by Siemens application engineer required.

| Selection and Ordering data | Order No. | Order No. |
|--|----------------------------------|--|
| Milltronics MCS Belt Scale A compact, rugged, modular, heavy-duty belt scale for use in mining and aggregate screening plants | C) 7MH7125-0 | C) 7MH7125-0 |
| Scale construction Standard duty Hazardous Duty CSA/FM Class II, Div. 1, Groups E,F,G and Class III, ATEX II 2D, IECEx, CE, C-TICK | 1 2 | C) 7ML1998-5HN63 |
| Load cell capacity 50 lb (22.7 kg) (use not recommended for mobile crushers) 100 lb (45.5 kg) (use not recommended for mobile crushers) 250 lb (113.6 kg) 500 lb (226.8 kg) 25 lb (11.3 kg) (use not recommended for mobile crushers) Not specified ¹⁾ | AA AB AC AD AE BB | C) 7ML1998-5GA01 C) 7ML1998-5GA11 C) 7ML1998-5GA31 C) 7ML1998-5GA21 C) 7ML1998-5KH81 |
| Fabrication Polyester painted mild steel Polyester painted mild steel, for use with flat bar calibration | 1 2 | |
| Further designs Please add "-Z" to Order No. and specify Order code(s). Stainless Steel tag [69 x 38 mm (2.7 x 1.5 inch)], Measuring-point number / identification (max 16 characters), specify in plain text. Manufacturer's Test Certificate: According to EN 10204-2.2 | Order Code Y15 C11 | |
| | | Milltronics MCS Belt Scale A compact, rugged, modular, heavy-duty belt scale for use in mining and aggregate screening plants |
| | | Operating Instructions MCS Belt Scale, Multi-language <u>Belt Scale Application Guidelines</u> English French German Spanish Hazardous location certificates Note: The Operating Instructions should be ordered as a separate item on the order. This device is shipped with the Siemens Milltronics manual CD containing the complete Operating Instructions library. |
| | | Spare parts <u>Stainless steel load cell</u> [17-4 PH (1.4568) stainless steel construction with 304 (1.4301) stainless steel cover] 25 lb (11.3 kg) 50 lb (22.7 kg) 100 lb (45.4 kg) 250 lb (113.4 kg) 500 lb (226.8 kg) 25 lb (11.3 kg), CSA/FM/ATEX/IECEX 50 lb (22.7 kg), CSA/FM/ATEX/IECEX 100 lb (45.4 kg), CSA/FM/ATEX/IECEX 250 lb (113.4 kg), CSA/FM/ATEX/IECEX 500 lb (226.8 kg), CSA/FM/ATEX/IECEX Conduit replacement kit |
| | | C) 7MH7725-1DR C) 7MH7725-1DH C) 7MH7725-1DJ C) 7MH7725-1DK C) 7MH7725-1DS C) 7MH7725-1DQ C) 7MH7725-1DL C) 7MH7725-1DM C) 7MH7725-1DN C) 7MH7725-1DP C) 7MH7723-1NA |
| | | Calibration Weights Flat bar/MWL retrofit kit Calibration (Test) Arm Assembly, with one 18 lb calibration weight Calibration (Test) Arm Assembly, with two 18 lb calibration weight MBS/MCS Calibration Arm with idler clip (holds up to 2 of 8.2 kg weights) Calibration weight, 18 lb (8.2 kg) Calibration weight, 6 lb (2.7 kg) Milltronics flat bar calibration weights, see page 4/57 Note: Calibration accessories should be ordered as a separate item on the order. |
| | | C) 7MH7723-1HA 7MH7723-1FR 7MH7723-1FS 7MH7726-1AD 7MH7724-1AA 7MH7724-1AB |
| | | ¹⁾ Only for quotation purposes, not a valid ordering option. C) Subject to export regulations AL: N, ECCN: EAR99. Note: Calibration weight and calibration weight bracket are not included in MCS belt scale. |

Belt Scales

Milltronics Belt Scales

Milltronics MCS

Dimensional drawings

4

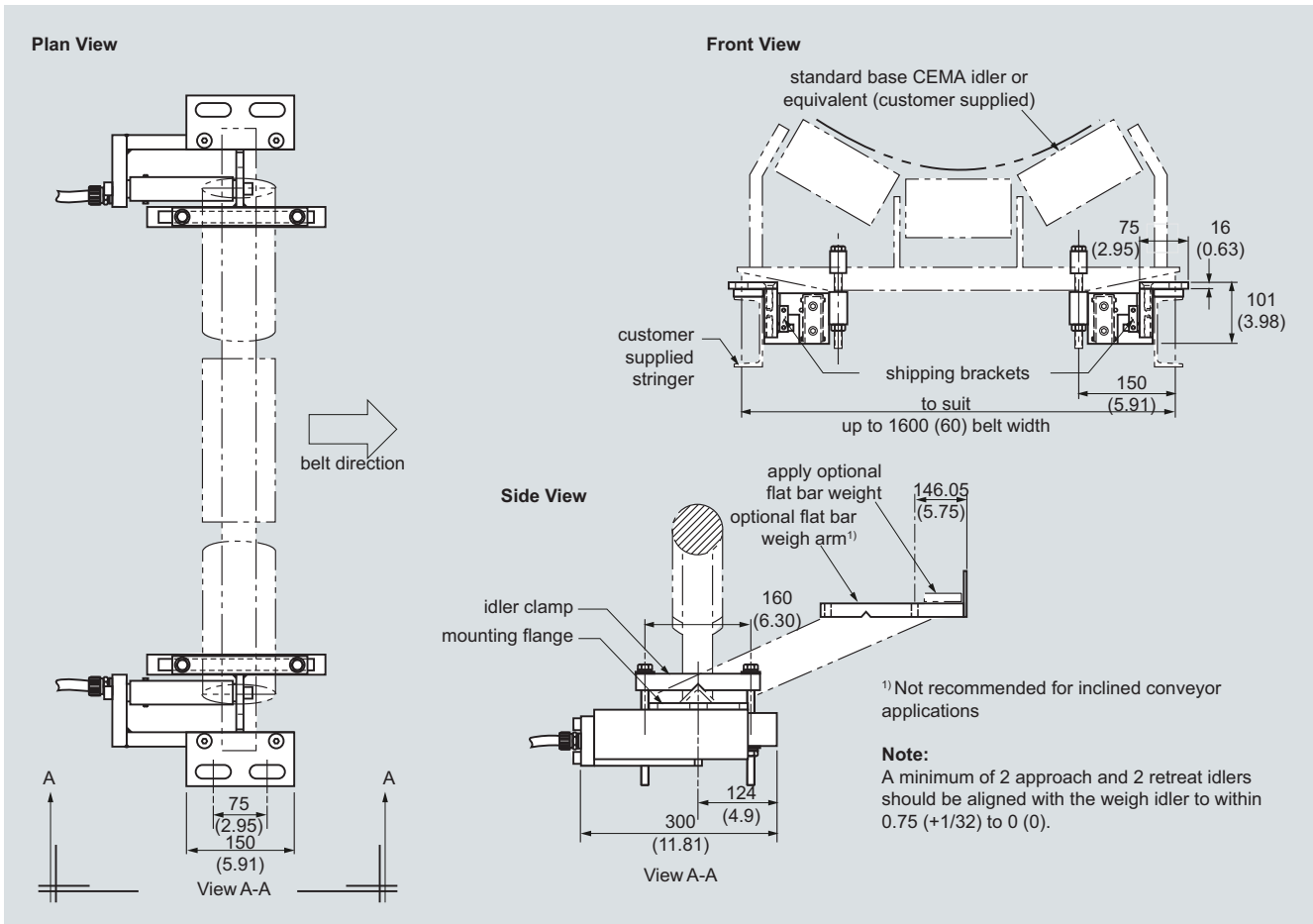

MCS dimensions in mm (inch)

Schematics

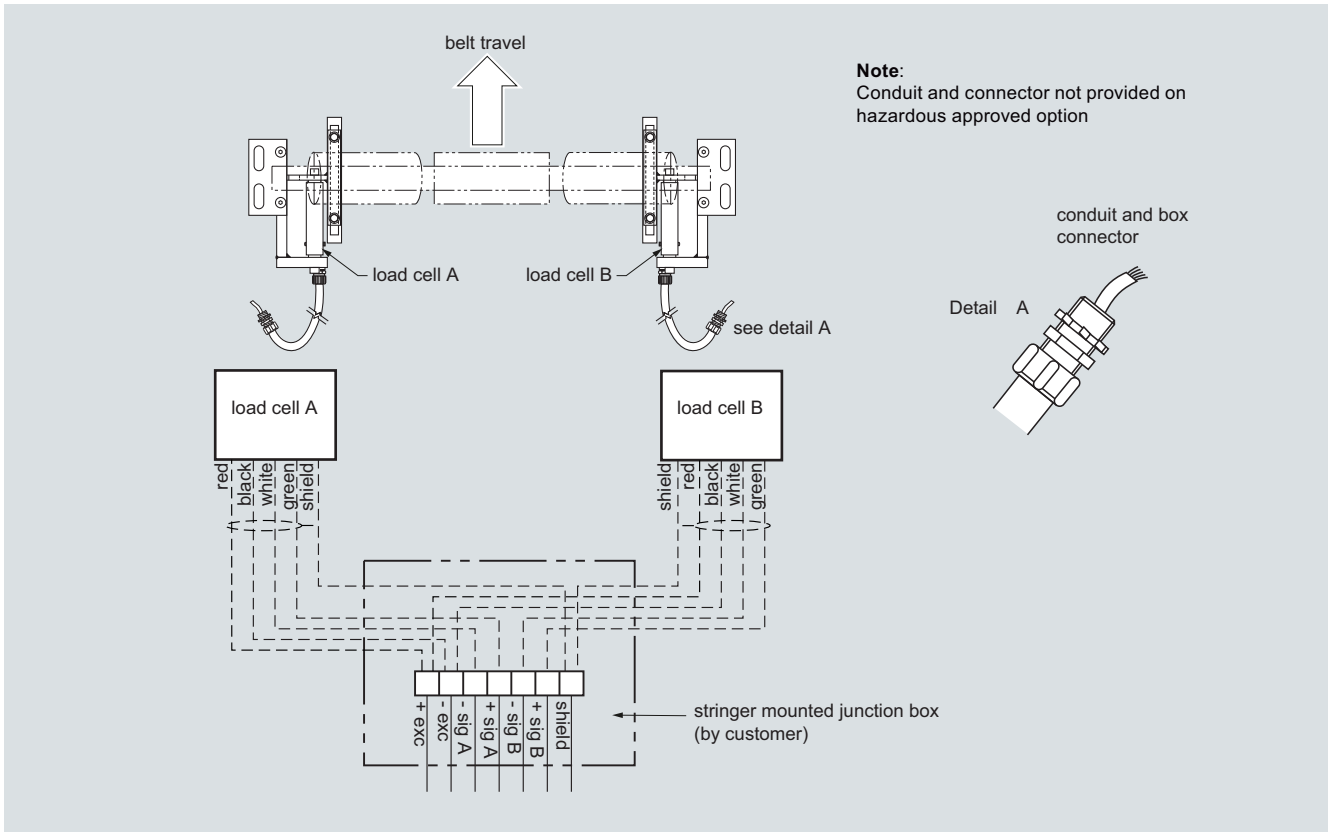

MCS connections

Belt Scales

Milltronics Belt Scales

Milltronics MSI and MMI

Overview



Milltronics MSI is a heavy-duty, high accuracy full-frame single idler belt scale used for process and load-out control. Idler not included with belt scale.



Milltronics MMI is a heavy-duty, high accuracy multiple idler belt scale used for critical process and load-out control. Idler not included with belt scale.

Benefits

Milltronics MSI belt scale

- Outstanding accuracy and repeatability
- Unique parallelogram style load cell design
- Fast reaction to product loading; capable of monitoring fast moving belts
- Rugged construction
- SABS approval (South Africa), OIML, MID, and Measurement Canada

Milltronics MMI belt scale

- Exceptional accuracy and repeatability
- Unique parallelogram style load cell design
- Suitable for uneven or light product loading
- Capable of monitoring fast moving belts
- Low cost of ownership
- NTEP, OIML, MID and Measurement Canada approved

Application

Milltronics MSI belt scale

Milltronics MSI belt scale provides continuous in-line weighing on a variety of products in primary and secondary industries. It is proven in a wide range of tough applications from extraction (in mines, quarries and pits), to power generation, iron and steel, food processing and chemicals. The MSI is suitable for monitoring such diverse products as sand, flour, coal, or sugar.

The MSI's patented use of parallelogram-style load cells results in fast reaction to vertical forces, ensuring instant response to product loading. This enables it to provide outstanding accuracy and repeatability even with uneven loading and fast belt speeds.

Operating with Milltronics BW100, BW500, or SIWAREX FTC microprocessor-based integrators, the MSI provides indication of flow rate, totalized weight, belt load, and belt speed of bulk solid materials. A speed sensor monitors conveyor belt speed for input to the integrator.

The MSI is installed in a simple drop-in operation and may be secured with just four bolts. An existing idler is then attached to the MSI dynamic beam. With no moving parts, maintenance is kept to a minimum, with just periodic calibration checks required.

Milltronics MMI belt scale

Milltronics MMI belt scale consists of two or more MSI single idler belt scales installed in series. It provides high accuracy continuous in-line weighing on a variety of products in primary and secondary industries. The MMI system is proven in a wide range of tough applications from extraction to power generation, iron and steel, food processing and chemicals. The MMI is suitable for monitoring such diverse products as fertilizer, sand, grain, flour, coal, or sugar.

The MMI's patented use of parallelogram-style load cells results in fast reaction to vertical forces, ensuring instant response to product loading. This enables it to provide outstanding accuracy and repeatability even with uneven or light loading, short idler spacing and fast belt speeds. Operating with Milltronics BW500 or SIWAREX FTC integrator (for custody transfer applications), the MMI provides indication of flow rate, total weight, belt load and belt speed of bulk solids materials on a belt conveyor. A speed sensor monitors conveyor belt speed for input to the integrator.

The MMI is installed in a simple drop-in operation and may be secured with just eight bolts and existing idler sets, secured to the dynamic beam. With no moving parts, maintenance is kept to a minimum, with just periodic calibration checks required.

Design

Note:
Conduit and cable arrangement may differ from example shown

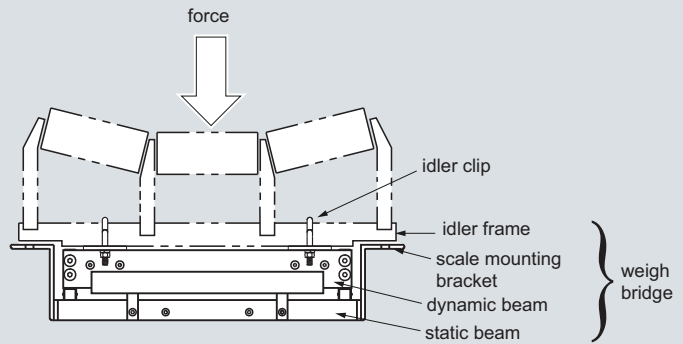
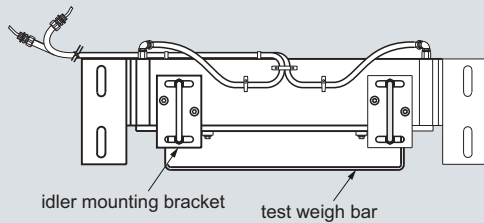

MSI/MMI mounting

Applications with 2 MSIs (MMI-2)

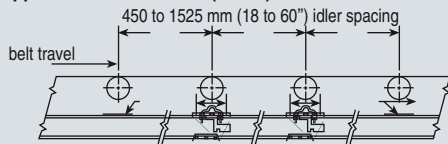

Applications with 3 MSIs (MMI-3)

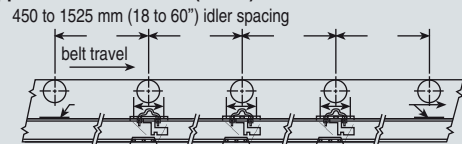

Mounting (two or more MSI units), dimensions in mm (inch)

Belt Scales

Milltronics Belt Scales

Milltronics MSI and MMI

Technical specifications

Milltronics MSI and MMI

Mode of operation

Measuring principle Strain gauge load cells measuring load on belt conveyor idler(s)

Typical application

- MSI Control in fractionated stone blending tunnels
- MMI Custody transfer

Measurement accuracy

Accuracy¹⁾

- MSI $\pm 0.5\%$ or better of totalization over 20 ... 100 % operating range
- MMI-2 (2 idler) $\pm 0.25\%$ or better of totalization over 20 ... 100 % operating range
- MMI-3 (3 idler) $\pm 0.125\%$ or better of totalization over 25 ... 100 % operating range

Note: available with system specification option D only

Medium conditions

Material temperature -40 ... +75 °C (-40 ... +167 °F)

Belt design

- Belt width
- 18 ... 96 inch in CEMA sizes
 - Equivalent to 500 ... 2000 mm in metric size
 - Refer to dimensions section

Belt speed Up to 5 m/s (1000 fpm)²⁾

Capacity

Up to 12000 t/h (13200 STPH) at maximum belt speed. Please contact a Siemens representative for higher rates.

Conveyor incline

- $\pm 20^\circ$ from horizontal, fixed incline
- Up to $\pm 30^\circ$ with reduced accuracy³⁾

Idlers

- Idler profile
- Flat to 35°
 - Up to 45° with reduced accuracy³⁾
- Idler diameter 50 ... 180 mm (2 ... 7 inch)
- Idler spacing 0.5 ... 1.5 m (1.5 ... 5.0 ft)

Load cell

| | |
|------------------------------|---|
| Construction | 17-4 PH (1.4568) stainless steel construction with 304 (1.4301) stainless steel cover. |
| Degree of protection | IP67 |
| Excitation | 10 V DC nominal, 15 V DC maximum |
| Output | 2 ± 0.002 mV/V excitation (nominal) at rated load cell capacity |
| Non-linearity and hysteresis | 0.02 % of rated output |
| Non-repeatability | 0.01 % of rated output |
| Capacity | |
| • Maximum ranges | 50, 100, 250, 500, 750, 1000, 1250, 1500 lb |
| Overload | 150 % of rated capacity, ultimate 300 % of rated capacity |
| Temperature | <ul style="list-style-type: none"> • -40 ... +75 °C (-40 ... +167 °F) operating range • -18 ... +65 °C (0 ... 150 °F) compensated |

Weight

See dimensions drawings see page 4/26

Interconnection wiring (to integrator, per MSI)

< 150 m (500 ft) 18 AWG (0.75 mm²) 6 conductor shielded cable

> 150 m ... 300 m (500 ft ... 1000 ft) 18 ... 22 AWG (0.75 ... 0.34 mm²), 8 conductor shielded cable

Approvals

- CSA/FM Class II, Div. 1, Groups E,F,G and Class III
- ATEX II 2D Ex tD A21 IP65 T90 °C
- IECEx Ex tD A21 IP65 T90 °C
- CE, C-TICK, GOST, CMC

Metrology approvals

Measurement Canada, MID, OIML, SABS⁴⁾, NTEP⁵⁾

¹⁾ Accuracy subject to: On factory approved installations the belt scale system's totalized weight will be within the specified accuracy when compared to a known weighed material test sample. The test rate must be within the specified range of the design capacity and held constant for the duration of the test. The minimum material test sample must be equivalent to a sample obtained at the test flow rate for three revolutions of the belt or at least ten minutes running time, whichever is greater.

²⁾ Contact Siemens application engineering for consideration of higher belt speeds.

³⁾ Review by Siemens application engineer required.

⁴⁾ MSI only

⁵⁾ MMI only

| Selection and Ordering data | Order No. | Order No. |
|--|--|--|
| Milltronics MSI Belt Scale A heavy-duty, high-accuracy single idler belt scale for process and load-out control. For Milltronics MMI belt scale system, two or more MSI belt scales are required. Calibration weights are required and ordered as separate items. | C) 7MH7122- | C) 7MH7122- |
| Scale construction Standard duty Hazardous Duty CSA/FM Class II, Div. 1, Groups E,F,G and Class III, ATEX II 2D, IECEx, CE, C-TICK | 1 2 | |
| Belt width and 'A' dimension 18 inch, 'A' = 27 inch (686 mm) 19 inch, 'A' = 28 inch (711 mm) 20 inch, 'A' = 29 inch (737 mm) 21 inch, 'A' = 30 inch (762 mm) 22 inch, 'A' = 31 inch (787 mm) 23 inch, 'A' = 32 inch (813 mm) 24 inch, 'A' = 33 inch (838 mm) 25 inch, 'A' = 34 inch (864 mm) 26 inch, 'A' = 35 inch (889 mm) 27 inch, 'A' = 36 inch (914 mm) 28 inch, 'A' = 37 inch (940 mm) 29 inch, 'A' = 38 inch (965 mm) 30 inch, 'A' = 39 inch (991 mm) 31 inch, 'A' = 40 inch (1016 mm) 32 inch, 'A' = 41 inch (1041 mm) 33 inch, 'A' = 42 inch (1067 mm) 34 inch, 'A' = 43 inch (1092 mm) 35 inch, 'A' = 44 inch (1118 mm) 36 inch, 'A' = 45 inch (1143 mm) 37 inch, 'A' = 46 inch (1168 mm) 38 inch, 'A' = 47 inch (1194 mm) 39 inch, 'A' = 48 inch (1219 mm) 40 inch, 'A' = 49 inch (1245 mm) 41 inch, 'A' = 50 inch (1270 mm) 42 inch, 'A' = 51 inch (1295 mm) 43 inch, 'A' = 52 inch (1321 mm) 44 inch, 'A' = 53 inch (1346 mm) 45 inch, 'A' = 54 inch (1372 mm) 46 inch, 'A' = 55 inch (1397 mm) 47 inch, 'A' = 56 inch (1422 mm) 48 inch, 'A' = 57 inch (1448 mm) 49 inch, 'A' = 58 inch (1473 mm) 50 inch, 'A' = 59 inch (1499 mm) 51 inch, 'A' = 60 inch (1524 mm) 52 inch, 'A' = 61 inch (1549 mm) 53 inch, 'A' = 62 inch (1575 mm) 54 inch, 'A' = 63 inch (1600 mm) 55 inch, 'A' = 64 inch (1626 mm) 56 inch, 'A' = 65 inch (1651 mm) 57 inch, 'A' = 66 inch (1676 mm) 58 inch, 'A' = 67 inch (1702 mm) 59 inch, 'A' = 68 inch (1727 mm) 60 inch, 'A' = 69 inch (1753 mm) 61 inch, 'A' = 70 inch (1778 mm) 62 inch, 'A' = 71 inch (1803 mm) | AA AB AC AD AE AF AG AH AJ AK AL AM AN AP AQ AR AS AT AU AV AW BA BB BC BD BE BF BG BH BJ BK BL BM BN BP BQ BR BS BT BU BV BW CA CB CC | Milltronics MSI Belt Scale A heavy-duty, high-accuracy single idler belt scale for process and load-out control. For Milltronics MMI belt scale system, two or more MSI belt scales are required. Calibration weights are required and ordered as separate items. |
| | | 63 inch, 'A' = 72 inch (1829 mm) 64 inch, 'A' = 73 inch (1854 mm) 65 inch, 'A' = 74 inch (1880 mm) 66 inch, 'A' = 75 inch (1905 mm) 67 inch, 'A' = 76 inch (1930 mm) 68 inch, 'A' = 77 inch (1956 mm) 69 inch, 'A' = 78 inch (1981 mm) 70 inch, 'A' = 79 inch (2007 mm) 71 inch, 'A' = 80 inch (2032 mm) 72 inch, 'A' = 81 inch (2057 mm) 73 inch, 'A' = 82 inch (2083 mm) 74 inch, 'A' = 83 inch (2108 mm) 75 inch, 'A' = 84 inch (2134 mm) 76 inch, 'A' = 85 inch (2159 mm) 77 inch, 'A' = 86 inch (2184 mm) 78 inch, 'A' = 87 inch (2210 mm) 79 inch, 'A' = 88 inch (2235 mm) 80 inch, 'A' = 89 inch (2261 mm) 81 inch, 'A' = 90 inch (2286 mm) 82 inch, 'A' = 91 inch (2311 mm) 83 inch, 'A' = 92 inch (2337 mm) 84 inch, 'A' = 93 inch (2362 mm) 85 inch, 'A' = 94 inch (2388 mm) 86 inch, 'A' = 95 inch (2413 mm) 87 inch, 'A' = 96 inch (2438 mm) 88 inch, 'A' = 97 inch (2464 mm) 89 inch, 'A' = 98 inch (2489 mm) 90 inch, 'A' = 99 inch (2515 mm) 91 inch, 'A' = 100 inch (2540 mm) 92 inch, 'A' = 101 inch (2565 mm) 93 inch, 'A' = 102 inch (2591 mm) 94 inch, 'A' = 103 inch (2616 mm) 95 inch, 'A' = 104 inch (2642 mm) 96 inch, 'A' = 105 inch (2667 mm) |
| | | CD CE CF CG CH CJ CK CL CM CN CP CQ CR CS CT CU CV CW DA DB DC DD DE DF DG DH DJ DK DL DM DN DP DQ DR |
| | | Load cell capacity Not specified ¹⁾ 50 lb (22.7 kg) 100 lb (45.4 kg) 250 lb (113.4 kg) 500 lb (226.8 kg) 750 lb (340.2 kg) 1000 lb (453.6 kg) 1250 lb (567 kg) ²⁾ 1500 lb (680.4 kg) |
| | | 0 1 2 3 4 5 6 7 8 |

Belt Scales

Milltronics Belt Scales

Milltronics MSI and MMI

Selection and Ordering data (continued)

| | Order No. |
|--|--------------------|
| Milltronics MSI Belt Scale A heavy-duty, high-accuracy single idler belt scale for process and load-out control. For Milltronics MMI belt scale system, two or more MSI belt scales are required. Calibration weights are required and ordered as separate items. | C) 7MH7122- |
| Fabrication | |
| Polyester painted mild steel | 1 1 |
| <u>Electro-galvanized mild steel:</u> | |
| 18 ... 29 inch (457.2 to 736.6 mm) | 1 2 |
| 30 ... 41 inch (762 to 1041.4 mm) | 1 3 |
| 42 ... 53 inch (1066.8 to 1346.2 mm) | 1 4 |
| 54 ... 65 inch (1371.6 to 1651 mm) | 1 5 |
| 66 ... 77 inch (1676.4 to 1955.8 mm) | 1 6 |
| 78 ... 89 inch (1981.2 to 2260.6 mm) | 1 7 |
| 90 ... 96 inch (2786 to 2438.4 mm) | 1 8 |
| <u>Stainless steel 304 (1.4301), for belt width scales:</u> | |
| 18 ... 29 inch (457.2 to 736.6 mm) | 2 1 |
| 30 ... 41 inch (762 to 1041.4 mm) | 2 2 |
| 42 ... 53 inch (1066.8 to 1346.2 mm) | 2 3 |
| 54 ... 65 inch (1371.6 to 1651 mm) | 2 4 |
| 66 ... 77 inch (1676.4 to 1955.8 mm) | 2 5 |
| 78 ... 89 inch (1981.2 to 2260.6 mm) | 2 6 |
| 90 ... 96 inch (2786 to 2438.4 mm) | 2 7 |
| <u>Stainless steel 316 (1.4401), for belt width scales:</u> | |
| 18 ... 29 inch (457.2 to 736.6 mm) | 3 1 |
| 30 ... 41 inch (762 to 1041.4 mm) | 3 2 |
| 42 ... 53 inch (1066.8 to 1346.2 mm) | 3 3 |
| 54 ... 65 inch (1371.6 to 1651 mm) | 3 4 |
| 66 ... 77 inch (1676.4 to 1955.8 mm) | 3 5 |
| 78 ... 89 inch (1981.2 to 2260.6 mm) | 3 6 |
| 90 ... 96 inch (2786 to 2438.4 mm) | 3 7 |
| Polyester painted mild steel (compatible with MWL or flat bar weight calibration system) | 4 1 |
| <u>Galvanized, for belt width scales:</u> (compatible with MWL or flat bar weight system) | |
| 18 ... 29 inch (457.2 to 736.6 mm) | 4 2 |
| 30 ... 41 inch (762 to 1041.4 mm) | 4 3 |
| 42 ... 53 inch (1066.8 to 1346.2 mm) | 4 4 |
| 54 ... 65 inch (1371.6 to 1651 mm) | 4 5 |
| 66 ... 77 inch (1676.4 to 1955.8 mm) | 4 6 |
| 78 ... 89 inch (1981.2 to 2260.6 mm) | 4 7 |
| 90 ... 96 inch (2786 to 2438.4 mm) | 4 8 |
| System specification | |
| Standard MSI and MMI | A |
| NTEP Certified MMI ⁽³⁾⁽⁴⁾⁽⁵⁾ | B |
| OIML/MID Certified ⁽³⁾⁽⁶⁾ | C |
| MSI for MMI-3 ±0.125% accuracy ⁽⁴⁾ | D |
| Further designs | Order Code |
| Please add "-Z" to Order No. and specify Order code(s). | |
| Stainless Steel tag [69 x 38 mm (2.7 x 1.5 inch)], Measuring-point number / identification (max 16 characters), specify in plain text. | Y15 |
| Manufacturer's Test Certificate: According to EN 10204-2.2 | C11 |

Order No.

| | |
|--|-------------------------|
| Milltronics MSI Belt Scale A heavy-duty, high-accuracy single idler belt scale for process and load-out control. For Milltronics MMI belt scale system, two or more MSI belt scales are required. Calibration weights are required and ordered as separate items. | C) 7MH7122- |
| Operating Instructions | |
| MSI Manuals | |
| • English | C) 7ML1998-5CY02 |
| • German | C) 7ML1998-5CY11 |
| • French | C) 7ML1998-1CY11 |
| • Spanish | C) 7ML1998-1CY21 |
| MMI Manuals | |
| • English | C) 7ML1998-5DR03 |
| • German | C) 7ML1998-5DR33 |
| Belt Scale Application Guidelines | |
| • English | C) 7ML1998-5GA01 |
| • French | C) 7ML1998-5GA11 |
| • German | C) 7ML1998-5GA31 |
| • Spanish | C) 7ML1998-5GA21 |
| • Hazardous location certificates | C) 7ML1998-5KH81 |
| Note: The Operating Instructions and application guidelines manual should be ordered as separate items on the order. | |
| This device is shipped with the Siemens Milltronics manual CD containing the complete Operating Instructions library. | |
| Spare parts | |
| Flat bar/MWL retrofit kit | C) 7MH7723-1FW |
| Conduit replacement kit | 7MH7723-1NA |
| <u>Stainless steel load cell</u> [17-4 PH (1.4568) stainless steel construction with 304 (1.4301) stainless steel cover] | |
| 50 lb (22.7 kg) | C) 7MH7725-1AC |
| 100 lb (45.4 kg) | C) 7MH7725-1AD |
| 250 lb (113.4 kg) | C) 7MH7725-1AE |
| 500 lb (226.8 kg) | C) 7MH7725-1AF |
| 750 lb (340.2 kg) | C) 7MH7725-1AG |
| 1000 lb (453.6 kg) | C) 7MH7725-1AH |
| 1250 lb (567 kg) | C) 7MH7725-1EA |
| 1500 lb (680.4 kg) | C) 7MH7725-1EB |
| 100 lb (45.4 kg), NTEP, OIML/MID | C) 7MH7725-1DB |
| 250 lb (113.4 kg), NTEP, OIML/MID | C) 7MH7725-1DC |
| 500 lb (226.8 kg), NTEP, OIML/MID | C) 7MH7725-1DD |
| 750 lb (340.2 kg), NTEP, OIML/MID | C) 7MH7725-1DE |
| 1000 lb (453.6 kg), NTEP, OIML/MID | C) 7MH7725-1DF |
| 50 lb (22.7 kg), CSA/FM/ATEX/IECEX | C) 7MH7725-1DT |
| 100 lb (45.4 kg), CSA/FM/ATEX/IECEX | C) 7MH7725-1DU |
| 250 lb (113.4 kg), CSA/FM/ATEX/IECEX | C) 7MH7725-1DV |
| 500 lb (226.8 kg), CSA/FM/ATEX/IECEX | C) 7MH7725-1DW |
| 750 lb (340.2 kg), CSA/FM/ATEX/IECEX | C) 7MH7725-1DX |
| 1000 lb (453.6 kg), CSA/FM/ATEX/IECEX | C) 7MH7725-1DY |
| 1250 lb (567 kg), CSA/FM/ATEX/IECEX | C) 7MH7725-1EE |
| 1500 lb (680.4 kg), CSA/FM/ATEX/IECEX | C) 7MH7725-1EF |

| Selection and Ordering data (continued) | Order No. |
|---|---|
| Milltronics MSI Belt Scale A heavy-duty, high-accuracy single idler belt scale for process and load-out control. For Milltronics MMI belt scale system, two or more MSI belt scales are required. Calibration weights are required and ordered as separate items. | C) 7MH7122-  |
| Idler Clip 5 inch (127 mm) for 27 ... 62 inch (686 ... 1 575 mm) 'A' dimensions | 7MH7723-1BT |
| 7 inch (178 mm) for 63 ... 74 inch (1 600 ... 1 880 mm) 'A' dimensions | 7MH7723-1DF |
| Calibration Weights 6.0 lb / 2.7 kg 18 lb / 8.2 kg Milltronics flat bar calibration weights, see page 4/57 | 7MH7724-1AB 7MH7724-1AA |

- 1) Only for quotation purposes, not a valid ordering option
 - 2) Available with Fabrication options 11 to 18 and 41 to 48 only, and with System specification option A only.
 - 3) Two MSI are required to make the NTEP approved MMI
 - 4) Approval available with load cell options 2 to 6 only and applicable BW500
 - 5) Complete specification data sheet on page 4/4 and submit with order "legal for trade" version
 - 6) Includes metrological approved loadcells
- C) Subject to export regulations AL: N, ECCN: EAR99.

Belt Scales

Milltronics Belt Scales

Milltronics MSI and MMI

Dimensional drawings

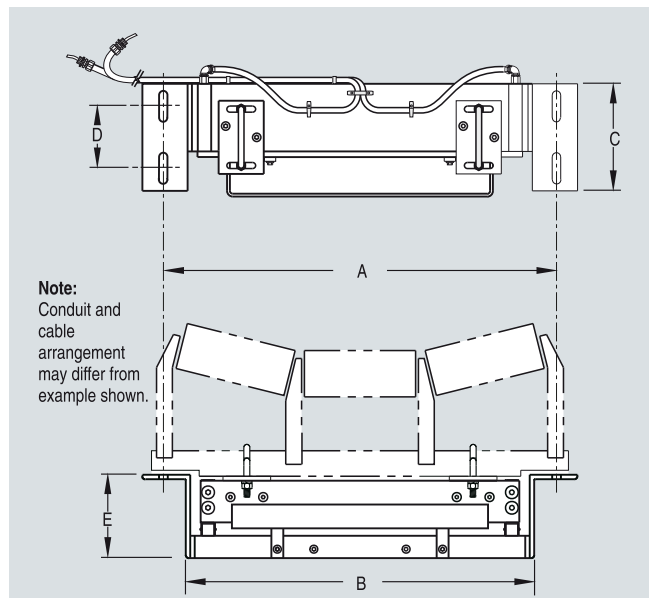

MSI dimensions

| Conveyor belt width | Mounting scale width 'A' | Minimum drop-in width 'B' | 'C' | 'D' | 'E' | Weight (approx.) |
|----------------------|--------------------------|---------------------------|----------------------|----------------------|--------------------|--------------------|
| 18 inch (457 mm) | 27 inch (686 mm) | 23.25 inch (591 mm) | 9.5 inch (241 mm) | 5.5 inch (140 mm) | 7 inch (178 mm) | 82 lb (37 kg) |
| 20 inch (508 mm) | 29 inch (737 mm) | 25.25 inch (641 mm) | 9.5 inch (241 mm) | 5.5 inch (140 mm) | 7 inch (178 mm) | 85 lb (39 kg) |
| 24 inch (610 mm) | 33 inch (838 mm) | 29.25 inch (743 mm) | 9.5 inch (241 mm) | 5.5 inch (140 mm) | 7 inch (178 mm) | 90 lb (41 kg) |
| 30 inch (762 mm) | 39 inch (991 mm) | 35.25 inch (895 mm) | 9.5 inch (241 mm) | 5.5 inch (140 mm) | 7 inch (178 mm) | 99 lb (45 kg) |
| 36 inch (914 mm) | 45 inch (1143 mm) | 41.25 inch (1048 mm) | 9.5 inch (241 mm) | 5.5 inch (140 mm) | 7 inch (178 mm) | 107 lb (49 kg) |
| 42 inch (1067 mm) | 51 inch (1295 mm) | 47.25 inch (1200 mm) | 9.5 inch (241 mm) | 5.5 inch (140 mm) | 7 inch (178 mm) | 116 lb (53 kg) |
| 48 inch (1219 mm) | 57 inch (1448 mm) | 53.25 inch (1353 mm) | 9.5 inch (241 mm) | 5.5 inch (140 mm) | 7 inch (178 mm) | 125 lb (57 kg) |
| 54 inch (1372 mm) | 63 inch (1600 mm) | 59.25 inch (1505 mm) | 12 inch (305 mm) | 8 inch (203 mm) | 7 inch (178 mm) | 175 lb (79 kg) |
| 60 inch (1524 mm) | 69 inch (1753 mm) | 65.25 inch (1657 mm) | 12 inch (305 mm) | 8 inch (203 mm) | 7 inch (178 mm) | 193 lb (88 kg) |
| 66 inch (1676 mm) | 75 inch (1905 mm) | 71.25 inch (1810 mm) | 12 inch (305 mm) | 8 inch (203 mm) | 8 inch (203 mm) | 229 lb (104 kg) |
| 72 inch (1829 mm) | 81 inch (2057 mm) | 77.25 inch (1962 mm) | 12 inch (305 mm) | 8 inch (203 mm) | 8 inch (203 mm) | 247 lb (112 kg) |

Other widths available - check selection- and ordering data at page 4/23. Sizes are from 18 inch (457 mm) to 96 inch (2438 mm) in 1 inch (25.4 mm) increments. All sizes are nominal.

Note: Dimension B must be approx. 3/8 inch or 10 mm less than Y dimension of the conveyor (see Questionnaire on page 4/3).

Schematics

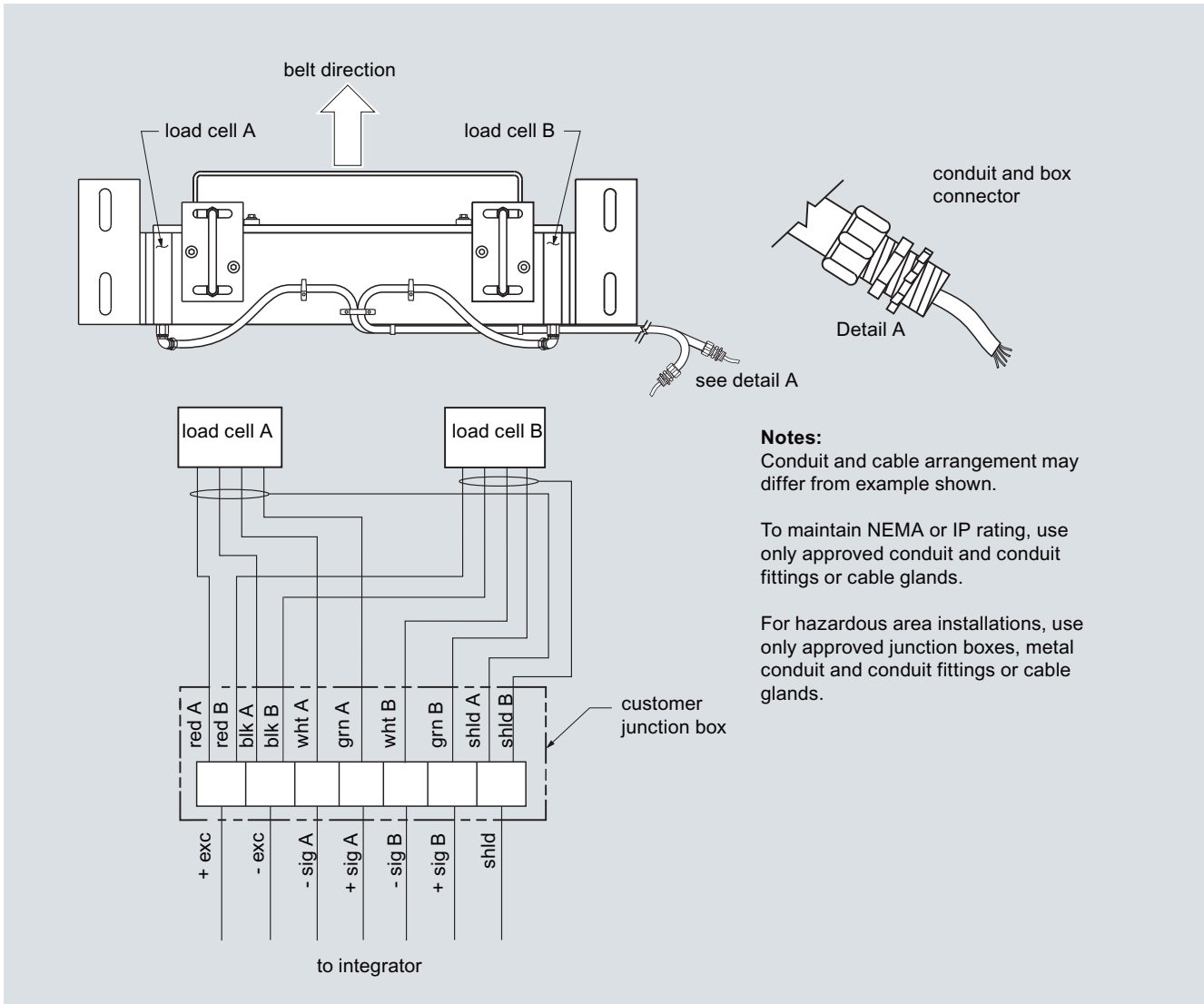

MSI/MMI connections

Belt Scales

Milltronics Belt Scales

Milltronics MSI and MMI

More information

NTEP/Measurement Canada/OIML & MID Specification Data

| Please complete and submit the relevant details listed below when ordering NTEP, Measurement Canada, or OIML & MID approval options | Value |
|---|-------|
| <i>NTEP</i> | |
| Maximum rated capacity (TPH) | |
| Minimum rated capacity (TPH) | |
| Belt speed (FPM) | |
| Scale division (tons) | |
| Maximum loading (lb/ft) | |
| <i>Measurement Canada</i> | |
| Rate | |
| Speed (min/max m/s, FPM) | |
| Test load (kg/m, lb/ft) | |
| <i>OIML & MID</i> | |
| Totalization scale interval (tonnes) | |
| Belt speed max, min (m/s) | |
| Maximum flow rate (MTPH) | |
| Minimum flow rate (MTPH) | |
| Minimum totalized load (tonnes) | |
| Product to be weighed | |
| Maximum capacity (tonnes) | |
| Weight length (m) | |
| Ratio between minimum net load and maximum capacity | |
| Zero testing should have a duration of at least (____) revolutions | |

Belt Scales

Milltronics Belt Scales

Milltronics WD600

Overview



Milltronics WD600 is a light- to medium-duty slider bed belt scale used for process and load-out control in manufacturing, including the food, pharmaceutical and tobacco industries.

Benefits

- Simple installation
- Long weigh span for more retention time on load cells

Application

WD600 works with an existing flat belt conveyor and the selected Siemens integrator. As material is moving along the conveyor belt and travels over the belt scale, it exerts a force proportional to the material load through the suspended weighbridge to the load cells.

WD600 reacts only to the vertical component of the applied force. The resulting movement in each load cell is sensed by its strain gauges. When the strain gauges are excited by voltage from the electronic integrator, they produce an electrical signal proportional to weight, which is then applied to the integrator.

The vertical movement of the load cells is limited by the positive overload stop incorporated into the design of the load cell mount.

Technical specifications

| Milltronics WD600 | |
|--------------------------------------|--|
| Accuracy¹⁾ | ± 0.5 ... 1 % totalization over 25 ... 100 % operating range, application dependent |
| Belt width | 12, 18, 24, 30, 36, 42, 48 inch (300, 450, 600, 750, 900, 1000, 1200 mm) |
| Belt speed | 2.0 m/s (400 fpm) maximum ²⁾ |
| Capacity | Up to 100 t/h |
| Conveyor incline | <ul style="list-style-type: none"> • ± 20 ° from horizontal, fixed incline • Up to ± 30 ° with reduced accuracy³⁾ |
| Conveyor idler/slider profile | Horizontal |
| Loading | <ul style="list-style-type: none"> • Minimum 1.0 kg/m (0.6 lb/ft) • Maximum 76 kg/m (51 lb/ft) |
| Load cell | |
| Construction | 17-4 PH (1.4568) stainless steel or nickel plated alloy steel |
| Degree of protection | <ul style="list-style-type: none"> • Stainless steel: IP68 • Nickel plated alloy steel: IP66 |
| Excitation | 10 V DC nominal, 15 V DC maximum |
| Output | 2 mV/V |
| Non-linearity | 0.02 % of rated output |
| Non-repeatability | 0.01 % of rated output |
| Capacity | Stainless steel range: 6, 12, 30 kg Nickel-plated range: 10, 15, 20, 30, 50 kg |
| Overload | 150 % of rated capacity |
| Temperature | <ul style="list-style-type: none"> • -40 ... +65 °C (-40 ... +150 °F) operating range • -10 ... +40 °C (15 ... 105 °F) compensated |
| Scale construction | <ul style="list-style-type: none"> • Stainless steel construction • Acetal sliders |
| Hazardous locations | Consult the factory |
| Approvals | CE, meets FDA/USDA requirements for food processing, C-TICK |

¹⁾ Accuracy subject to: On factory approved installations the belt scale system's totalized weight will be within the specified accuracy when compared to a known weighed material test sample. The test rate must be within the specified range of the design capacity and held constant for the duration of the test. The minimum material test sample must be equivalent to a sample obtained at the test flow rate for three revolutions of the belt or at least ten minutes running time, whichever is greater.

²⁾ Contact Siemens application engineering for consideration of higher belt speeds.

³⁾ Review by Siemens application engineer required.

Belt Scales

Milltronics Belt Scales

Milltronics WD600

Selection and Ordering data

Milltronics WD600

A low- to medium- capacity scale for light to medium belt loading.
304 stainless steel construction with Delrin sliders. Load cells are available in nickle plated, or stainless steel. Two calibration weights are required and are ordered as separate line item. Refer to Calibration weights.

Belt width

12 inch (300 mm)
18 inch (450 mm)
24 inch (600 mm)
30 inch (750 mm)
36 inch (900 mm)
42 inch (1000 mm)
48 inch (1200 mm)

Load cell capacity

Nickel plated

10 kg (22 lb)
15 kg (33.1 lb)
20 kg (44 lb)

30 kg (66.2 lb)
50 kg (110 lb)

Stainless steel

6 kg (13.2 lb)
12 kg (26.4 lb)
30 kg (66.2 lb)

Further designs

Please add **"-Z"** to Order No. and specify Order code(s).

Stainless Steel tag [69 x 38 mm (2.7 x 1.5 inch)], Measuring-point number / identification (max 16 characters), specify in plain text.

Manufacturer's Test Certificate:
According to EN 10204-2.2

Order No.

C) 7MH7185-

A0

1
2
3
4
5
6
7D
E
F
G
L
H
J
K

Order Code

Y15

C11

Order No.

C) 7MH7185-

A0

Milltronics WD600

A low- to medium- capacity scale for light to medium belt loading.
304 stainless steel construction with Delrin sliders. Load cells are available in nickle plated, or stainless steel. Two calibration weights are required and are ordered as separate line item. Refer to Calibration weights.

Operating Instructions

- English

- German

[Belt Scale Application Guidelines](#)

- English

- French

- German

- Spanish

Note: The Operating Instructions should be ordered as a separate line on the order.

This device is shipped with the Siemens Milltronics manual CD containing the complete Operating Instructions library.

Spare parts

Load cells

Stainless steel

6 kg (13.2 lb)

12 kg (26.4 lb)

30 kg (66.2 lb)

Nickel plated

10 kg (22 lb)

15 kg (33.1 lb)

20 kg (44 lb)

30 kg (66.2 lb)

50 kg (110 lb)

Slider bar middle UHMW PE (for old style WD600)

Slider bar side UHMW PE (for old style WD600)

Slider bar acetal

Calibration Hanger Weights

200 g (0.4 lb)

500 g (1.1 lb)

1000 g (2.2 lb)

2000 g (4.4 lb)

3500 g (7.7 lb)

5000 g (11 lb)

7500 g (16.5 lb)

8500 g (18.7 lb)

10000 g (22 lb)

12000 g (26.5 lb)

15000 g (33.1 lb)

C) 7ML1998-5KM01

C) 7ML1998-5KM31

C) 7ML1998-5GA01

C) 7ML1998-5GA11

C) 7ML1998-5GA31

C) 7ML1998-5GA21

C) 7MH7725-1EG

C) 7MH7725-1EH

C) 7MH7725-1EJ

7MH7725-1EK

7MH7725-1EL

7MH7725-1EM

7MH7725-1EN

C) 7MH7725-1EP

7MH7723-1KF

7MH7723-1KE

7MH7723-1KG

C) 7MH7724-1AF

C) 7MH7724-1AG

C) 7MH7724-1AH

7MH7724-1AJ

7MH7724-1BQ

7MH7724-1AK

7MH7724-1BR

7MH7724-1BS

7MH7724-1BT

7MH7724-1BU

7MH7724-1BV

C) Subject to export regulations AL: N, ECCN: EAR99.

Dimensional drawings

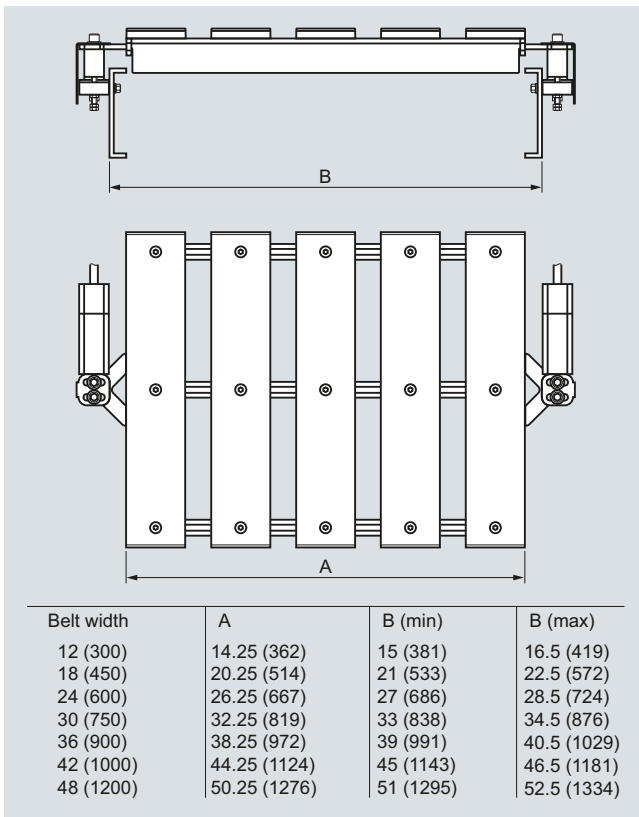

WD600, dimensions in inch (mm)

Belt Scales

Milltronics Belt Scales

Milltronics WD600

Schematics

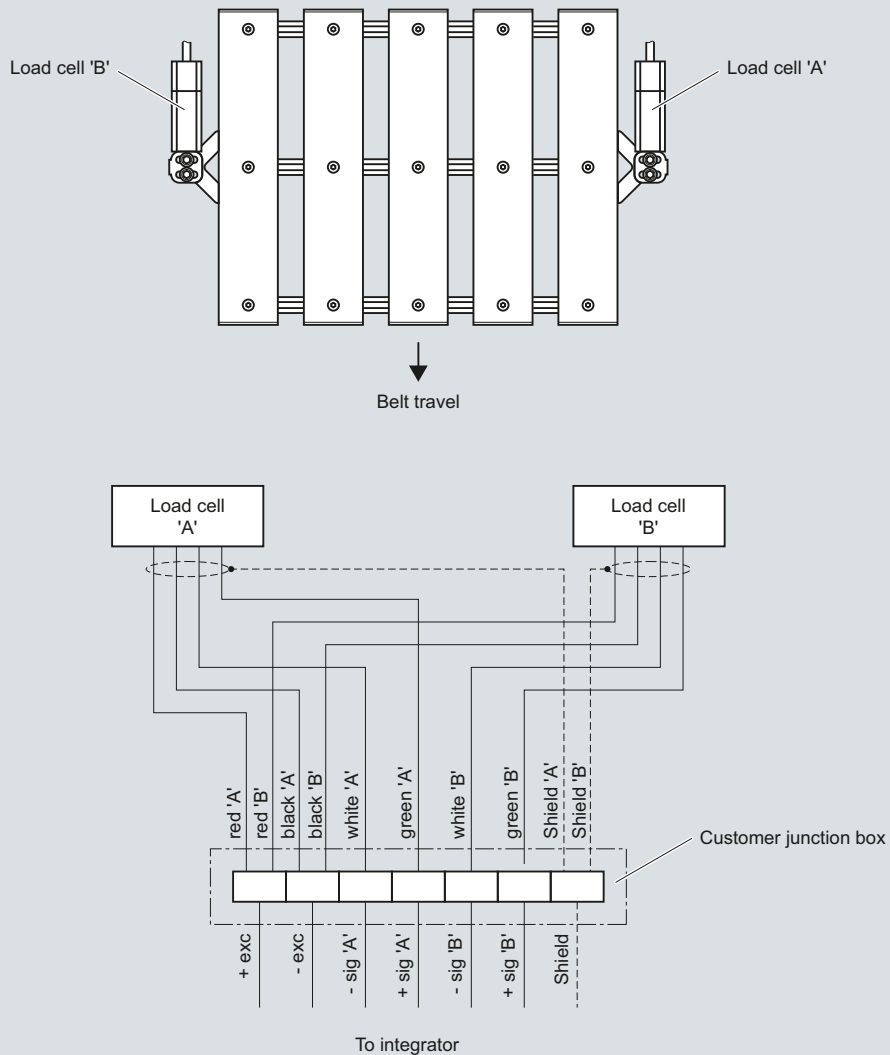

WD600 connections

4

Overview

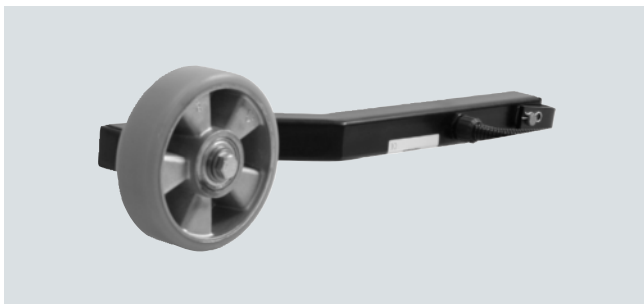

Milltronics TASS is a compact low-profile, wheel-driven return belt speed sensor, ideal for use on mobile crushers and in constricted spaces.

Benefits

- Rugged design
- Easy, low cost installation
- Compact, low-profile speed sensor
- IP67 rated

Application

Milltronics TASS speed sensor operates in conjunction with a conveyor belt scale, providing signals to an integrator (Milltronics BW100, BW500, or SIWAREX FTC) which computes the rate of material being conveyed. The trailing arm speed sensor monitors conveyor belt speed, with the output signal transmitted by cable connection to the integrator.

Easily installed close to the belt scale assembly, the TASS provides a signal generated as the wheel rotates on the return belt. Pulses are generated by the internal proximity switch detecting the rotation of the five spoked wheel. The TASS is mounted to the static beam of the belt scale or to a structural cross member via a pivoting bracket assembly.

The TASS is a compact, low-profile, rugged speed sensor, most often used on mobile crusher applications where space is limited. The TASS output can be applied to any Milltronics belt scale integrator.

Design

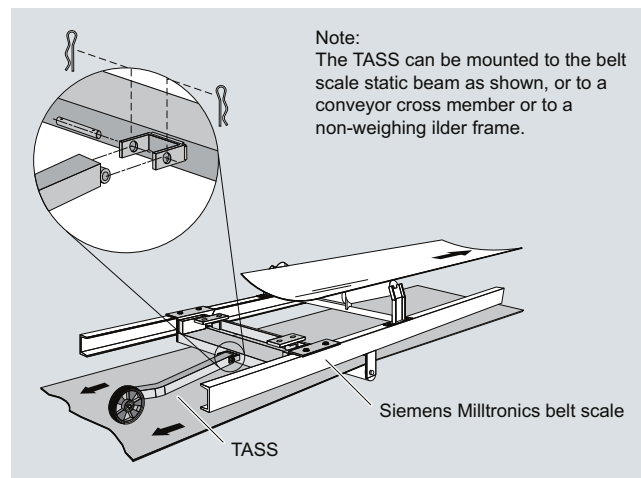

TASS Installation

Technical specifications

| Milltronics TASS | |
|---|--|
| Mode of operation | |
| Measuring principle | Proximity sensor provides pulse to integrator |
| Typical application | Mobile crusher |
| Input | |
| | <ul style="list-style-type: none"> • Bi-directional wheel rotation • 25 ... 350 rpm |
| Output | |
| | <ul style="list-style-type: none"> • Inductive proximity sensor • Open collector, NPN, sinking output, max. 200 mA • Pulses: 5 per revolution • 9.947 pulses/m, 3.03 pulses/ft |
| Rated operating conditions | |
| Operating temperature | -25 ... +70 °C (-13 ... +158 °F) |
| Degree of protection | IP67 |
| Design | |
| Trailing arm assembly | Painted mild steel |
| Wheel | 160 mm (6.3 inch) diameter cast aluminum with polyurethane tread |
| Power supply | |
| | 10 ... 35 V DC, 15 mA at 24 V DC maximum |
| Wiring | |
| Brown | + Excitation (10 ... 35 V DC) |
| Black | + Signal |
| Blue | - Common |
| Interconnection wiring (to integrator) | |
| | <ul style="list-style-type: none"> • 2 m, 3 conductor shielded PVC cable, 3 x 0.25 mm² (23 AWG), protected with 1000 mm of flexible conduit • 300 m (1000 ft) maximum cable run |
| Approvals | |
| | CE, C-TICK |

Belt Scales

Speed Sensors

Milltronics TASS

Selection and Ordering data

Milltronics TASS Speed Sensor

Compact, low-profile, wheel driven return belt speed sensor for belt conveyors; ideal for use on mobile crushers and in constricted spaces.

Model

5 pulses per revolution

Fabrication

Standard, polyester painted mild steel
Stainless steel 304 (1.4301)
Note: Wheel is aluminum for all versions

Mounting options

Complete with standard mounting kit

Approvals

CE, C-TICK

Order No.

C) **7MH7131-**

0

1

A

B

A

1

Order No.

C) **7MH7131-**

0

Order Code

Y15

C11

Order No.

C) **7ML1998-5HL61**

Milltronics TASS Speed Sensor

Compact, low-profile, wheel driven return belt speed sensor for belt conveyors; ideal for use on mobile crushers and in constricted spaces.

Further designs

Please add **"-Z"** to Order No. and specify Order code(s).

Stainless Steel tag [69 x 38 mm (2.7 x 1.5 inch)]
Measuring-point number / identification (max 16 characters), specify in plain text.

Manufacturer's Test Certificate:
According to EN 10204-2.2

Operating Instructions

TASS Operating Instructions, Multi-language
Note: The Operating Instructions should be ordered as a separate item on the order.

This device is shipped with the Siemens Milltronics manual CD containing the complete Operating Instructions library.

Spare parts

TASS Wheel

7MH7723-1AN

TASS Proximity Switch

7MH7723-1AP

TASS Wheel, stainless steel sealed bearing

7MH7723-1GW

Conduit replacement kit

7MH7723-1NA

C) Subject to export regulations AL: N, ECCN: EAR99.

4

Dimensional drawings

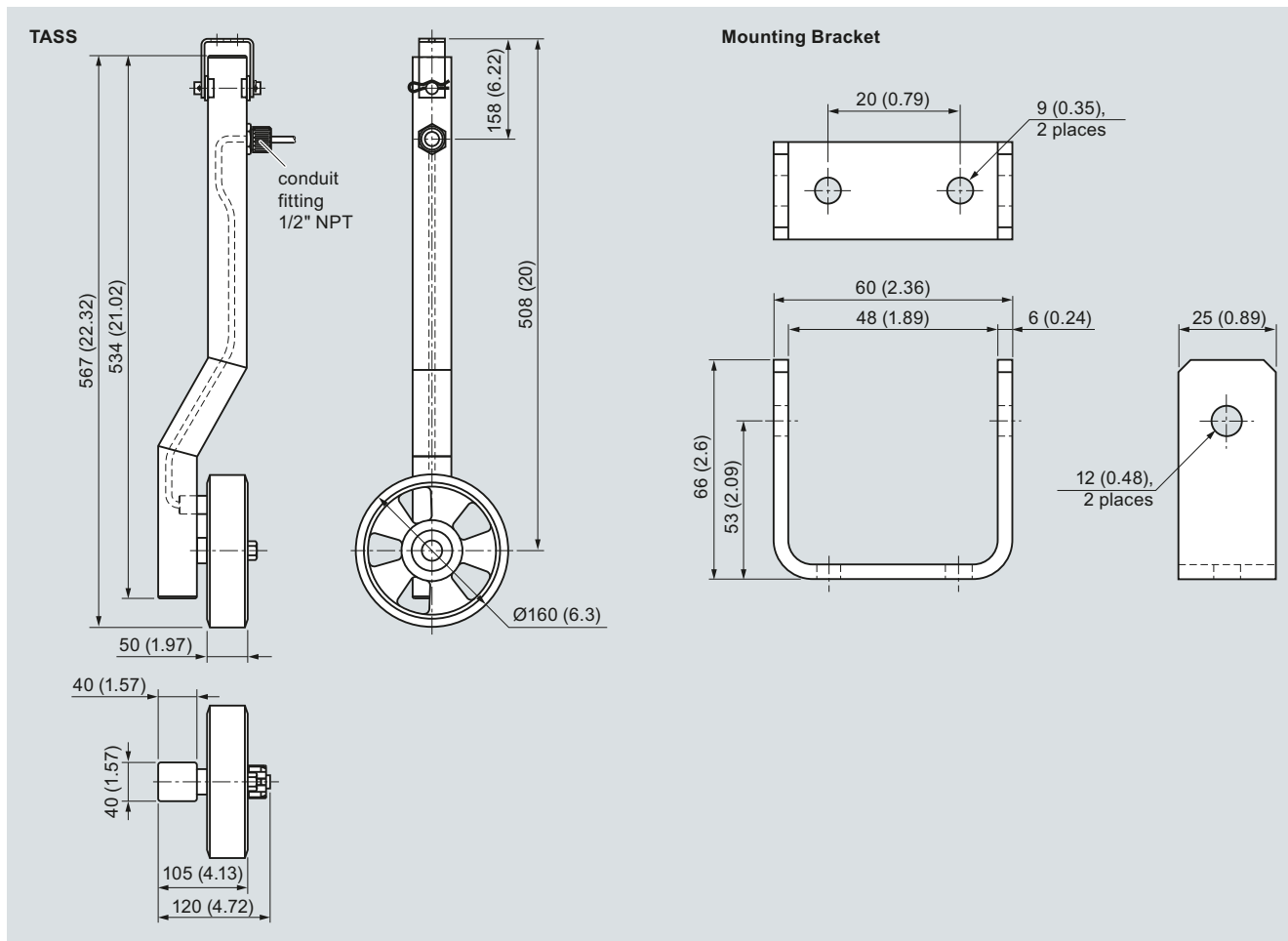

TASS dimensions in mm (inch)

Overview

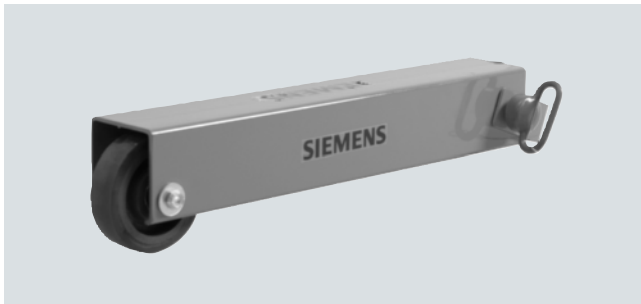

Milltronics RBSS is a high resolution, wheel-driven return belt speed sensor.

Benefits

- Rugged design
- IP67 rated
- Easy, low cost installation
- Accurate belt speed detection

Application

Milltronics RBSS monitors conveyor belt speed, with the output signal transmitted by cable connection to the integrator (Milltronics BW100, BW500, or SIWAREX FTC).

Easily installed close to the belt scale assembly, the RBSS provides a signal generated as the wheel on the sensor rotates on the return belt. To secure this cost-effective unit in place, position a cross bar between stringers - either just before or after a return belt idler, or use the optional mounting bracket. The weight of the RBSS ensures positive rotation of the wheel in the middle of the return belt, and pulses from the magnetic sensor are generated by the rotation of the 60 toothed speed sprocket driven by the wheel.

The RBSS output can be applied to any Milltronics belt scale integrator.

Design

RBSS Standard Mounting

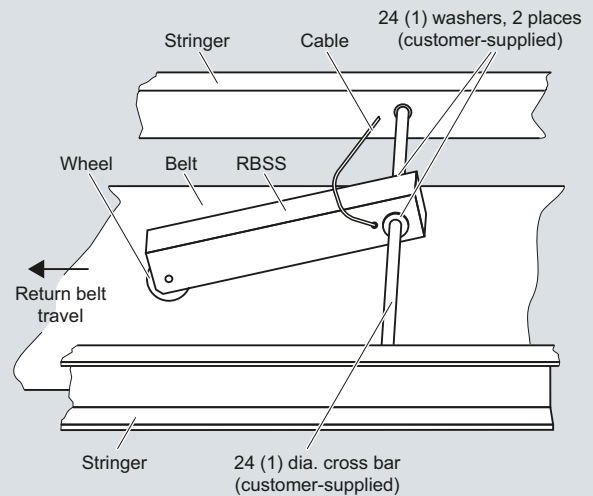

RBSS with Optional Mounting Bracket

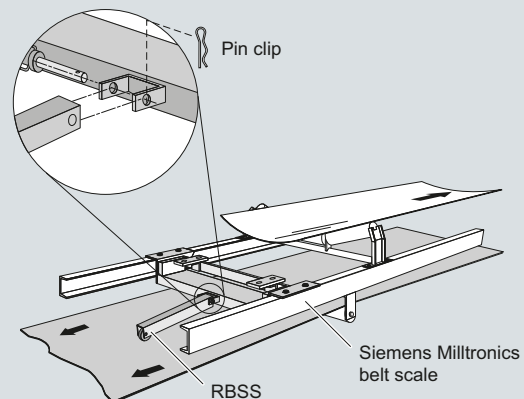

RBSS installation

Belt Scales

Speed Sensors

Milltronics RBSS

Technical specifications

Milltronics RBSS

Mode of operation

Measuring principle Proximity sensor provides pulse to integrator

Typical application Aggregate belt conveyors

Input Wheel rotation 2 ... 450 rpm, bi-directional

Output

- 60 pulses per revolution, 2 ... 450 Hz, 150.4 pulses/m (4.58 pulses/ft)
- RBSS: open collector sinking output, max. 17 mA
- RBSS IS: load current, 0 ... 15 mA

Rated operating conditions

Ambient temperature

- RBSS: -40 ... +105 °C (-40 ... +220 °F)
- RBSS IS: -25 ... +100 °C (-14 ... +212 °F)

Degree of protection IP67

Design

Trailing arm Painted mild steel

Sensor wheel 127 mm (5 inch) diameter, polyurethane tread

Power supply

- RBSS: 4.5 ... 28 V DC, 16 mA
- RBSS IS: 5 ... 25 V DC from IS switch isolator

Interconnection wiring (to integrator)

- RBSS: 3 m, 3 conductor 22 AWG shielded cable - 300 m (1000 ft) maximum cable run
- RBSS IS: 2 m, 2 conductor 26 AWG PVC covered cable - 300 m (1000 ft) maximum cable run to IS switch isolator - 300 m (1000 ft) maximum cable run from IS switch isolator and integrator

Approvals

RBSS CE, C-TICK¹⁾

RBSS IS (with suitable IS switch isolator or switch amplifier)²⁾

- ATEX II 1G Eex ia IIC T6
- ATEX II 1D Ex iaD 20 T 108 °C
- CSA/FM
- CE, C-TICK²⁾

Proximity switch approval ratings (Pepperl+Fuchs #NJ0.8-5GM-N)

- ATEX II 1G EEx ia IIC T6
- ATEX II 1D Ex iaD 20 T 108 °C
- CE, CSA, FM²⁾

Optional switch isolator (required for RBSS IS)³⁾

- Pepperl+Fuchs #KFA5-SOT2-Ex2 or #KFA6-SOT2-Ex2
- ATEX II (1) G [EEx ia] IIC
- CSA/FM: Class 1, Div. 1, Groups A, B, C, and D. Class II, Div. 1, Groups E, F, and G, Class III
- CE²⁾

¹⁾ EMC performance available upon request.

²⁾ Approvals for RBSS IS are based on internally mounted NAMUR slotted proximity switch (Pepperl+Fuchs #NJ0.8-5GM-N) and use of suitable IS switch isolator (amplifier). Please see RBSS operating Instructions for more information.

³⁾ Approval ratings for the proximity switch and IS switch isolator are the property of Pepperl+Fuchs. Copies of these Approval Certificates may be obtained at <http://www.siemens.com/processautomation>.

Selection and Ordering data

Order No.

Milltronics RBSS Speed Sensor

A high resolution wheel-driven return belt speed sensor

Model

60 pulses per revolution

Fabrication

Standard, polyester painted mild steel

Mounting options

With mounting kit

Approvals

CE, C-TICK, ATEX II 1G, EEx ia IIC T6, ATEX II 1D Ex iaD 20 T108 °C, CSA/FM
CE, C-TICK

Switch isolator

Not required

115 V AC¹⁾

230 V AC¹⁾

Further designs

Please add "-Z" to Order No. and specify Order code(s).

Stainless Steel tag [69 x 38 mm (2.7 x 1.5 inch)], Measuring-point number / identification (max 16 characters), specify in plain text.

Manufacturer's Test Certificate: According to EN 10204-2.2

Operating Instructions

RBSS Operating Instructions, Multi-language Note: The Operating Instructions should be ordered as a separate item on the order.

This device is shipped with the Siemens Milltronics manual CD containing the complete Operating Instructions library.

Spare parts

Wheel, 127 dia-polyurethane, sealed bearing

Proximity Switch

Switch, inductive, NJ0.8-5GM-N (Approvals option 2)¹⁾

P & F Switch Isolator, 115 V AC¹⁾

P & F Switch Isolator, 230 V AC¹⁾

Wheel and shaft, 152 mm dia.²⁾

60 tooth gear²⁾

Bearing (two required)²⁾

Conduit replacement kit

¹⁾ Required with RBSS IS

²⁾ For use with old style RBSS PBD-51033452

C) Subject to export regulations AL: N, ECCN: EAR99.

C) 7MH7134-

2

A

B

2

3

0

1

2

Order Code

Y15

C11

Order No.

C) 7ML1998-5GX63

C) 7MH7723-1FX

C) 7MH7723-1GA

C) 7MH7723-1AS

7MH7723-1EB

7MH7723-1EC

C) 7MH7723-1EN

C) 7MH7723-1EQ

C) 7MH7723-1ER

C) 7MH7723-1NA

Dimensional drawings

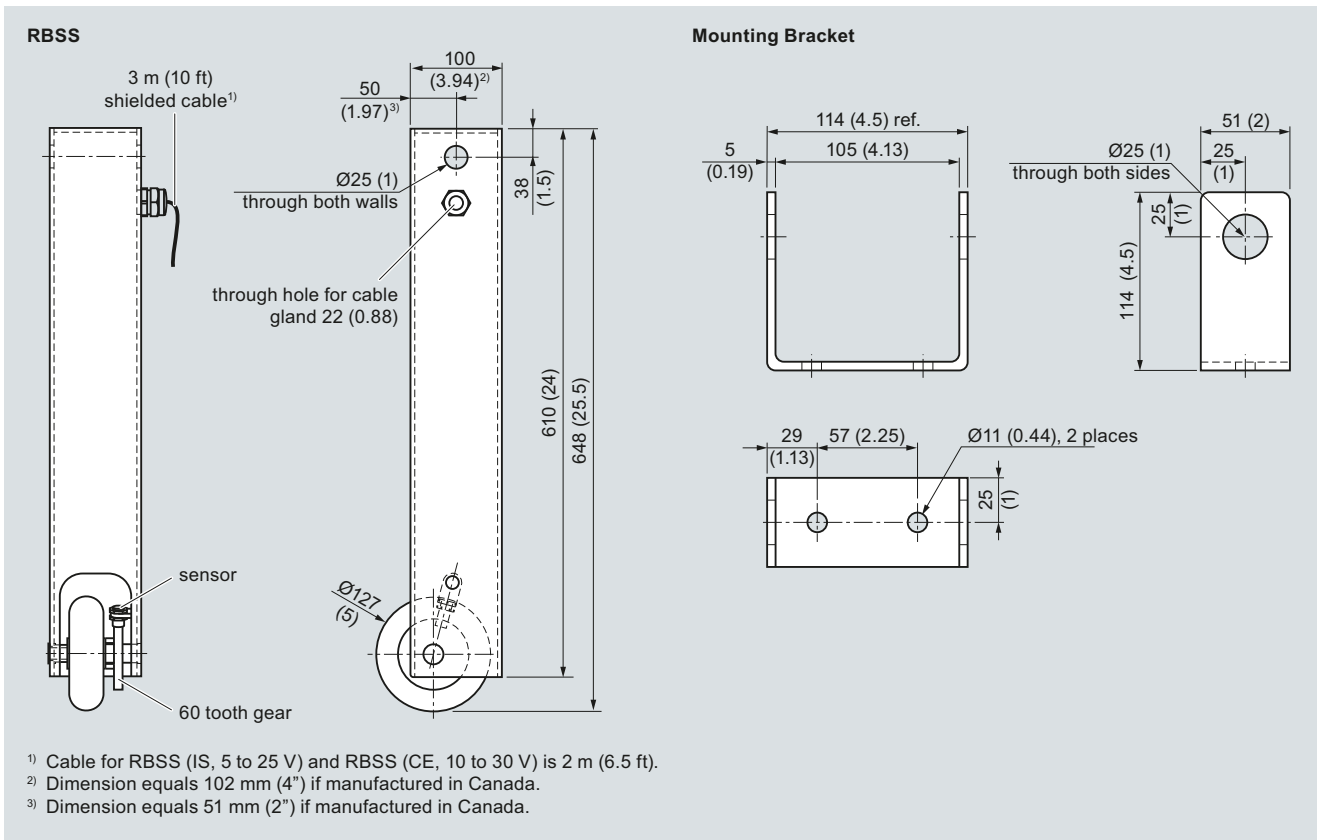

RBSS dimensions in mm (inch)

Belt Scales

Speed Sensors

SITRANS WS100

Overview



SITRANS WS100 speed sensor is a compact, medium-resolution, pulley shaft-driven belt speed sensor with magnetic mounting. It is ideal for aggregate and mineral processing industries.

Benefits

- Small, light-weight
- Good resolution for accurate measurement, suitable for varying shaft speeds
- Long bearing life

Application

SITRANS WS100 speed sensor operates in conjunction with a conveyor belt scale, providing a signal to an integrator (Milltronics BW100 or BW500, or SIWAREX FTC module) which computes the rate of material being conveyed. It is lightweight at 1.22 kg (2.68 lb) and durable, for easy installation and prolonged bearing life.

The WS100 converts shaft rotation into a pulse train of 8 pulses per revolution. These pulses are typically fed into a Milltronics belt scale integrator. The integrator interprets the pulses and uses them in the calculation of belt speed, flow rate, and material totalization. In non-belt scale applications, the WS100 can be used to monitor rotational speed when directly connected to a PLC.

The WS100 IS (intrinsically safe) version contains an inductive proximity switch which transmits the pulses via a switch isolator for hazardous area locations.

Design

The input shaft on the SITRANS WS100 is coupled to the rotating shaft on a belt-driven pulley with a tapped hole, and is externally supported. The unit's flexible arresting strap stops it from rotating with the shaft, without causing bearing stress, and can be fitted to any rigid member close to the sensor.

When mounting, ensure the unit and the pulley shaft are concentric to avoid stresses on the unit's bearings.

For mounting using the magnetic connector, ensure the face of the rotating shaft on the belt driven pulley is flat, and has no burrs or damage that may prevent flush mounting of the magnetic connector. Attach the SITRANS WS100 speed sensor to the shaft; the magnetic connector will center itself as the belt driven pulley rotates.

Design (continued)

Mounting to a Tail Pulley

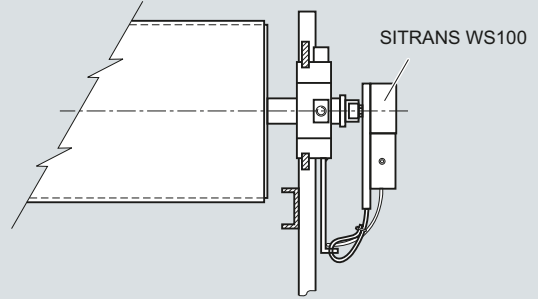
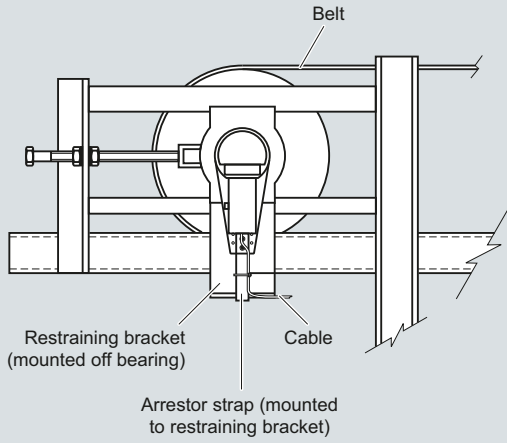

Mounting to a Bend or Snub Pulley

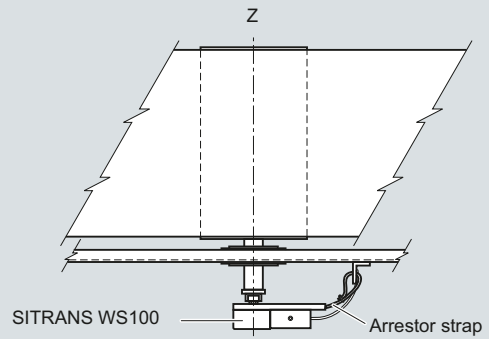
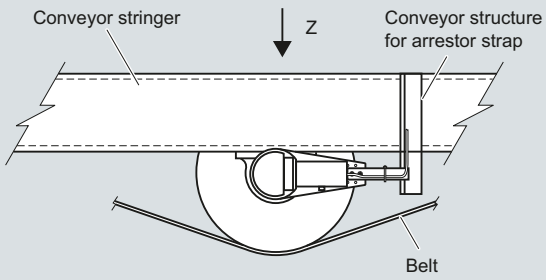

WS100 installation

Belt Scales

Speed Sensors

SITRANS WS100

Technical specifications

Milltronics WW100

Mode of operation

Measuring principle Proximity sensor provides pulse to integrator

Typical application

Aggregate belt conveyors

Input

Shaft rotation 15 ... 1500 rpm, bi-directional

Shaft rotation 15 ... 300 rpm, bi-directional with magnetic connector

Output

- 8 pulses per revolution
- 0 ... 200 Hz, 0 ... 40 Hz with magnetic connection
- WS100 standard: open collector sinking output, 25 mA
- WS100 IS: load current, 0 ... 15 mA
- Integrator minimum usable frequency 2 Hz

Rated operating conditions

Standard -40 ... +110 °C (-40 ... +230 °F)

Intrinsically Safe -25 ... +100 °C (-14 ... +212 °F)

Degree of protection IP67

Enclosure

Polypropylene base and target enclosure with 304 (1.4301) stainless steel access cover
304 (1.4301) stainless steel shaft, bearings and hardware

Power

Standard 4.5 ... 28 V DC, 16 mA

Intrinsically Safe 5 ... 25 V DC from IS switch isolator

Cable

Standard

- 3 m (10 ft), 3 conductor 22 AWG (0.324 mm²), PVC shielded cable
- 300 m (1000 ft) maximum cable run

Intrinsically Safe

- 2 m (6.5 ft), 2 conductor 26 AWG (0.129 mm²), PVC covered cable
- 300 m (1000 ft) maximum cable run to IS switch isolator
- 300 m (1000 ft) maximum cable run from IS switch isolator and integrator

Approvals

WS100

WS100 IS (with suitable IS switch isolator or switch amplifier)²⁾

Proximity Switch Approval Ratings (Pepperl+Fuchs #NCN4- 12GM35-N0)

Optional Switch Isolator (required for WS100 IS)³⁾

Pepperl+Fuchs #KFA5-SOT2-Ex2 or #KFA6-SOT2-Ex2

CE, C-TICK¹⁾

- ATEX II 1G EEx ia IIC T6
- ATEX II 1D Ex iaD 20 T 108 °C
- CSA/FM
- CE, C-TICK²⁾
- ATEX II 1G EEx ia IIC T6
- ATEX II 1D Ex iaD 20 T 108 °C
- CSA Class I, Div. 1, Groups A, B, C, and D, Class II, Div. 1, Groups E, F, and G, Class III (system approval)
- CE, FM²⁾

- ATEX II (1) G [EEx ia] IIC
- CSA/FM: Class 1, Div. 1, Groups A, B, C, and D, Class II, Div. 1, Groups E, F, and G, Class III
- CE²⁾

¹⁾ EMC performance available upon request.

²⁾ Approvals for RBSS IS are based on internally mounted NAMUR slotted proximity switch (Pepperl+Fuchs #NJ0.8-5GM-N) and use of suitable IS Switch Isolator (Amplifier). Please see RBSS Operating Instructions for more information.

³⁾ Approval ratings for the proximity switch and IS switch isolator are the property of Pepperl+Fuchs. Copies of these approval certificates may be obtained at <http://www.siemens.com/processautomation>.

| Selection and Ordering data | Order No. |
|---|---|
| SITRANS WS100 Speed Sensor A compact, medium-resolution, pulley shaft-driven belt speed sensor with magnetic mounting; ideal for aggregate and mineral processing industries. | C) 7MH7176- |
| Model 8 PPR | 1 |
| Fabrication Polycarbonate construction with 304 stainless steel sensor cover | A |
| Mounting M12X1.75 threaded shaft Magnetic connector | A B |
| Approvals Standard CE, C-TICK CE, C-TICK, ATEX II 1G, EEx ia IIC T6, ATEX II 1D Ex iaD 20 T 108 °C, and CSA/FM | 0 1 |
| Switch Isolator Not required 115 V AC (required with IS option 1) 230 V AC (required with IS option 1) | 0 1 2 |
| Further designs Please add " Z " to Order No. and specify Order code(s). Stainless Steel tag [69 x 38 mm (2.7 x 1.5 inch)], Measuring-point number / identification (max 16 characters), specify in plain text. Manufacturer's Test Certificate: According to EN 10204-2.2 | Order Code Y15 C11 |
| Operating Instructions SITRANS WS100, English SITRANS WS100, German Note: The Operating Instructions should be ordered as a separate item on the order. This device is shipped with the Siemens Milltronics manual CD containing the complete Operating Instructions library. | Order No. C) 7ML1998-5LU02 7ML1998-5LU31 |
| Spare Parts Switch, Standard Magnetic Pickup Switch, inductive, NJO.8-5GM-N for Approvals option 1 WS100 Magnetic Connector P & F Switch Isolator, 115 V AC, required for Approvals option 1 P & F Switch Isolator, 230 V AC, required for Approvals option 1 | C) 7MH7723-1GA C) 7MH7723-1AS C) 7MH7723-1GF 7MH7723-1EB 7MH7723-1EC |
| C) Subject to export regulations AL: N, ECCN: EAR99. | |

Belt Scales Speed Sensors

SITRANS WS100

Dimensional drawings

Dimensions

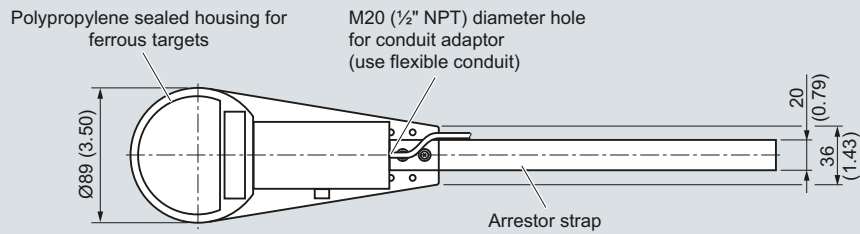

Magnetic shaft connector option

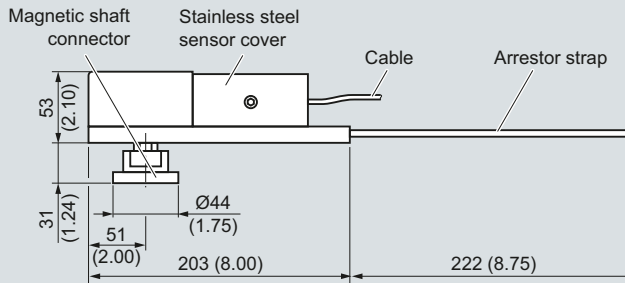

Male shaft connector option

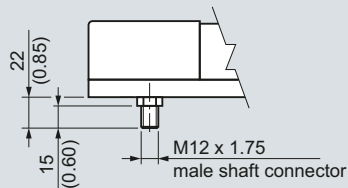

WS100 dimensions in mm (inch)

4

Overview



SITRANS WS300 is a low- to high-resolution shaft-driven speed sensor.

Benefits

- Compact and economical
- Easy, low-cost installation
- Accurate belt speed detection
- Optional resolutions for measurement over a range of belt speeds
- Corrosion resistant

Application

SITRANS WS300 speed sensor operates in conjunction with a conveyor belt scale, providing a signal to an integrator which computes the rate of material being conveyed. At only 1.22 kg (2.68 lb), it is one of the lightest and most durable units ever developed for monitoring conveyor belt speed. With its rugged cast aluminium housing, it is suitable for outdoor installation, and its low weight prolongs bearing life.

It is directly coupled to a rotating tail or bend pulley shaft to ensure accurate belt-travel readout, eliminating problems caused by belt slippage or material build-up. The WS300 converts shaft rotation into a pulse train of 32, 256, 1000, or 2000 pulses per revolution using a high precision rotary optical encoder. The digital signal is transmitted as speed input to any Siemens integrator for calculation of belt speed, flow rate and totalized weight.

This low- to high-resolution speed sensor provides a frequency signal proportional to the shaft speed, enabling a range of speeds to be read accurately. The quadrature type shaft encoder prevents erroneous speed signals due to vibration or shaft oscillation. The WS300 is easily mounted and is bi-directional for either clockwise or counter-clockwise belt travel.

The IS version uses an inductive proximity switch detecting rotating targets.

Belt Scales

Speed Sensors

SITRANS WS300

Design

Mounting to a Tail Pulley

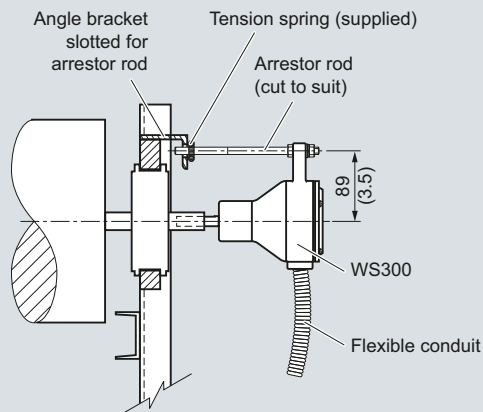
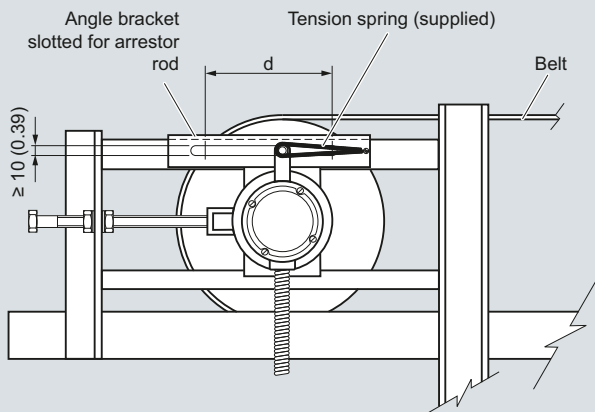

Notes:

Distance 'd' is the take-up travel on the tail pulley.

When adjusting the belt take-up, ensure that there is play on the arrestor rod. If the arrestor rod is pushed against the end of its travel slot, premature bearing wear may result.

Mounting to a Bend or Snub Pulley

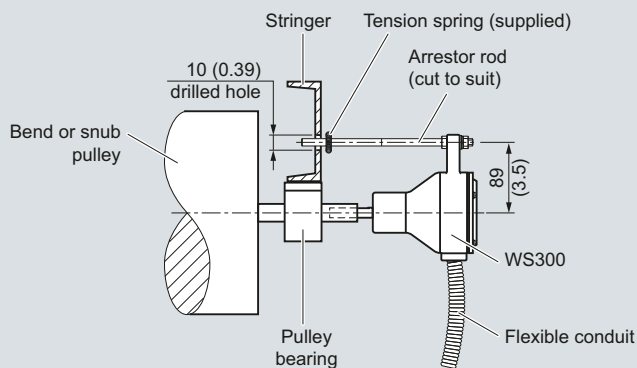
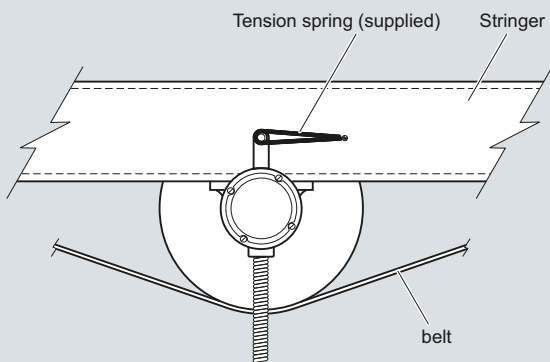

Notes:

When mounting to a bend or a snub pulley only, a 10 mm (0.39") drilled hole is required for the arrestor rod.

WS300 mounting, dimensions in mm (inch)

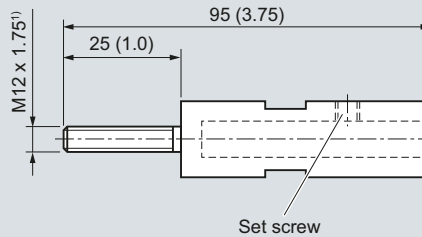
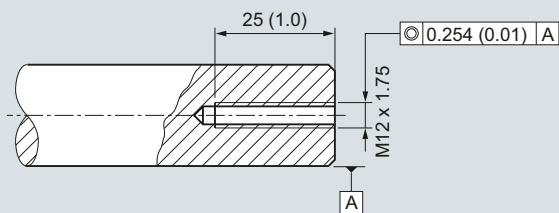

¹⁾ Use adhesive when installing threaded shaft coupling (e.g. Loctite).

WS300 mounting using threaded shaft coupling, dimensions in mm (inch)

4

Technical specifications

Milltronics WS300

Mode of operation

| | |
|---------------------|--|
| Measuring principle | Standard: pulse from shaft rotation using high precision rotary optical encoder IS: pulse from inductive proximity switch |
| Typical application | When a low- to high-resolution speed sensor is required |

Input

Shaft rotation 0.5 ... 2000 rpm, bi-directional, resolution dependent

Output

- Unidirectional open collector sinking output
- Standard: 10 ... 30 V DC, 25 mA max.
- IS: load current, 0 ... 15 mA
- 32, 256, 1000, or 2000 pulses per revolution (ppr)
- 32 ppr: 2000 max. rpm, 1066 Hz
- 256 ppr: 2000 max. rpm, 8530 Hz
- 1000 ppr: 900 max. rpm, 15000 Hz
- 2000 ppr: 450 max. rpm, 15000 Hz

Rated operating conditions

| | |
|----------------------|--|
| Ambient temperature | Standard: -40 ... +55 °C (-40 ... +131 °F) IS: -25 ... +60 °C (-13 ... +140 °F) |
| Degree of protection | NEMA 4X, Type 4X, IP65 |

Design

| | |
|-----------|--|
| Enclosure | <ul style="list-style-type: none"> • Rated NEMA 4X, Type 4X, IP65 • Painted aluminum • Stainless steel (optional) |
|-----------|--|

Power supply

- Standard: +10 ... +30 V DC, 60 mA max.
- IS: +5 ... +16 V DC, 25 mA max. (from IS switch isolator)

Cable

| | |
|-------------|--|
| Recommended | <ul style="list-style-type: none"> • Standard: 3-wire shielded, 0.82 mm² (18 AWG) • IS: 2-wire shielded 0.324 mm² (22 AWG) • Max. run 305 m (1000 ft) |
|-------------|--|

Approvals

WS300 Standard

General

Hazardous

WS300 IS (with suitable IS switch isolator or switch amplifier)¹⁾

Proximity switch approval ratings (Pepperl+Fuchs #NJ0.8-5GM-N)

Optional switch isolator (required for WS300 IS)³⁾

Pepperl+Fuchs #KFA5-SOT2-Ex2 or #KFA6-SOT2-Ex2

- CE, C-TICK
- CSA/FM Class II, Div. 1, Groups E, F, G; Class III
- ATEX II 2D Ex tD A21 IP65 T70 °C
- IECEx Ex tD A21 IP65 T70 °C
- ATEX II 1G EEx ia IIC T6
- ATEX II 1D Ex iaD 20 T 108 °C
- CSA/FM
- CE, C-TICK²⁾
- ATEX II 1G EEx ia IIC T6
- ATEX II 1D Ex iaD 20 T 108 °C
- CSA Class I, Div. 1, Groups A, B, C, and D, Class II, Div. 1, Groups E, F, and G, Class III (system approval)
- CE, FM²⁾
- ATEX II (1) G [EEx ia] IIC
- CSA/FM: Class 1, Div. 1, Groups A, B, C, and D. Class II, Div. 1, Groups E, F, and G, Class III
- CE²⁾

¹⁾ Approvals for WS300 IS are based on internally mounted NAMUR proximity switch (Pepperl+Fuchs #NJ0.8-5GM-N) and use of suitable IS switch isolator (amplifier). Please see WS300 operating instructions for more information.

²⁾ Approvals for RBSS IS are based on internally mounted NAMUR slotted proximity switch (Pepperl+Fuchs #NJ0.8-5GM-N) and use of suitable IS switch isolator (amplifier). Please see RBSS operating instructions for more information.

³⁾ Approval ratings for the proximity switch and IS switch isolator are the property of Pepperl+Fuchs. Copies of these approval certificates may be obtained at <http://www.siemens.com/processautomation>.

Belt Scales

Speed Sensors

SITRANS WS300

Selection and Ordering data

SITRANS WS300 Speed Sensor

A medium- to high-resolution shaft-driven speed sensor used used with Milltronics belt scales.

Resolution (pulses per revolution)

32
256
1000
2000¹⁾

Enclosure

Polyester painted aluminum, NEMA 4X
304 (1.4301) stainless steel, NEMA 4X

Approvals

CSA/FM Class II, Div. 1, Groups E, F, G Class III
ATEX II 2D, Ex tD A21 IP65 T70 °C,
CE, C-TICK, IECEX, Ex tD A21 IP65 T70 °C
CSA/FM, ATEX II 1G, EEx ia IIC T6, ATEX II 1D Ex
iaD 20 T108 °C, CE, C-TICK^{2) 3)}
CE, C-TICK

Connections

Standard, up to 2 integrators
Multiple, up to 10 integrators

Switch Isolator

Not required
115 V AC⁴⁾
230 V AC⁴⁾

Further designs

Please add **"-Z"** to Order No. and specify Order code(s).

Acrylic coated, stainless steel tag [13 x 45 mm (0.5 x 1.75 inch)]; Measuring-point number/identification (max. 16 characters), specify in plain text
Manufacturer's Test Certificate:
According to EN 10204-2.2

Order No.

C) **7MH7177-**

0

1

2

3

4

A

B

A

B

D

1

2

0

1

2

Order Code

Y17

C11

Order No.

C) **7MH7177-**

0

SITRANS WS300 Speed Sensor

A medium- to high-resolution shaft-driven speed sensor used used with Milltronics belt scales.

Operating Instructions

- English
- German

Note: The Operating Instructions should be ordered as a separate item on the order.

Spare parts

Circuit card 32 PPR, up to 2 integrators

Circuit card 32 PPR, up to 10 integrators

Circuit card 256 PPR, up to 2 integrators

Circuit card 256 PPR, up to 10 integrators

Circuit card 1000 PPR, up to 2 integrators

Circuit card 1000 PPR, up to 10 integrators

Circuit card 2000 PPR, up to 2 integrators

Circuit card 2000 PPR, up to 10 integrators

Circuit card 32 PPR, IS

Rubber coupling

Coupling hub for 32, 256 PPR versions

Coupling hub for 1000, 2000 PPR versions

Enclosure cover

Enclosure bearing assembly

Enclosure cover, stainless steel

Enclosure bearing assembly, stainless steel

Threaded shaft coupling

Arrestor rod

Arrestor rod tension spring

Cable for speed sensor connection to termination box 3 cond, 18G (order per meter)

Cable for IS speed sensor connection to termination box 3 cond, 22G (order per meter)

Pepperl+Fuchs IS switch isolator, 115 V AC

Pepperl+Fuchs IS switch isolator, 230 V AC

C) **7ML1998-5ML01**C) **7ML1998-5ML31**C) **7MH7723-1GK**C) **7MH7723-1GL**C) **7MH7723-1GM**C) **7MH7723-1GN**C) **7MH7723-1GP**C) **7MH7723-1GQ**C) **7MH7723-1JL**C) **7MH7723-1JM**C) **7MH7723-1HC**C) **7MH7723-1CM**C) **7MH7723-1CN****7MH7723-1GR****7MH7723-1CJ**C) **7MH7723-1CK**C) **7MH7723-1GS****7MH7723-1GT****7MH7723-1GH****7MH7723-1FV****7MH7723-1CP**C) **7MH7723-1JP**C) **7MH7723-1JQ****7MH7723-1EB****7MH7723-1EC**

¹⁾ Available with Approval option D only

²⁾ The Approval Ratings for the Proximity Switch and the IS Switch Isolator are the property of Pepperl+Fuchs. For current approvals, go to: <http://www.am.pepperl-fuchs.com>.

³⁾ Approval option B requires use of Switch Isolator to interface with the belt scale integrator, and is available with Resolution option 1, and Connections option 1 only.

⁴⁾ For use with IS approval option B

C) Subject to export regulations AL: N, ECCN: EAR99.

Dimensional drawings

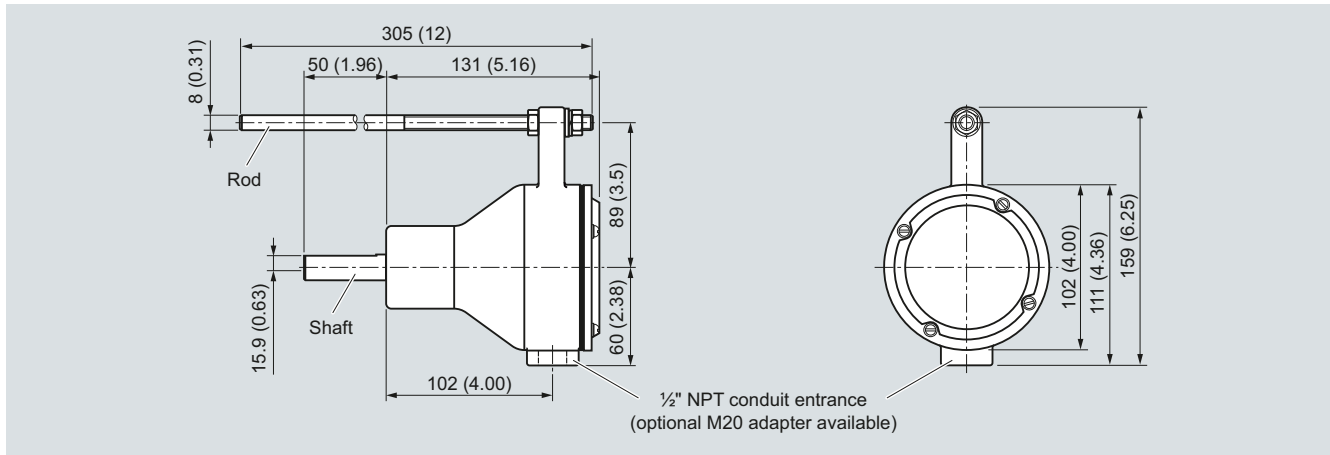

WS300 dimensions in mm (inch)

Schematics (Standard)

Connections

| Description | Terminal |
|-----------------|----------|
| +10 to +30 V DC | 1 |
| speed out-CW | 2 |
| speed out-CCW | 3 |
| common | 4 |
| ground | GND |

- Determine the pulley shaft rotation on the end of the pulley shaft to which the WS300 is attached.
- If the pulley shaft is rotating clockwise, connect the appropriate wire to terminal 2. If the pulley shaft is rotating counter-clockwise, connect the appropriate wire to terminal 3.
- Do not connect terminals 2 and 3 at the same time.
- Connection between the WS300 standard unit and the integrator should be made with three-wire shielded, 0.82 mm² (18 AWG) cable.
- Ground shield of cable at integrator only.
- Connect shield to appropriate terminal at the integrator.

Terminal Connections to Siemens Milltronics Integrators

| WS300 | 1 +V | 2 CW | 3 CCW | 4 Cmn | GND |
|-------------------|---------|---------|----------|----------|-----|
| Milltronics BW100 | 8 | 7 | 7 | 6 | N/C |
| Milltronics BW500 | 19 | 16 | 16 | 17 | N/C |

Terminal Connections to SIWAREX FTC Integrator

| WS300 | 1 +V | 2 CW | 3 CCW | 4 Cmn | GND |
|-------------|-----------------------|------------|------------|------------------------|-----|
| SIWAREX FTC | 24 V (back-plane bus) | X1.9 (CI+) | X1.9 (CI+) | X1.10 (CI- and Common) | N/C |

Schematics (IS)

Connections

| Description | Terminal |
|--|----------|
| +5 to +16 V DC, 25 mA max. (from IS Switch Isolator) | 1 |
| speed out | 2 |
| ground | GND |

- Only terminals 1 and 2 are required; rotation in a clockwise or counter-clockwise direction is not required.
- To connect the switch isolator, use two-wire shielded 0.324 mm² (22 AWG) cable. Use the same cable to connect the switch isolator to the integrator.
- Ground shield of cable at integrator only.
- Connect shield to appropriate terminal at the integrator.

Terminal Connections to Siemens Milltronics Integrators

| W300 IS | IS Switch Isolator Terminal | Integrator |
|---------|-----------------------------|--------------------|
| 1 | 1 | |
| 2 | 3 | |
| | 7 | speed signal input |
| | 8 | - excitation |

Terminal Connections to SIWAREX FTC Integrator

| W300 IS | IS Switch Isolator Terminal | Integrator |
|---------|-----------------------------|------------|
| 1 | 1 | |
| 2 | 3 | |
| | 7 | CI+ |
| | 8 | IL+ |

Connect CI- to Common

Belt Scales

Speed Sensors

Milltronics Bend Pulleys

Overview



Return belt driven pulley provides rotation for shaft-driven speed sensors. 4.5 inch size is self-cleaning.

Benefits

- Heavy-duty design for high belt tension
- Self cleaning 114 mm (4.5 inch) diameter option
- Steel drum 152 mm (6 inch) diameter option
- Steel drum 152 mm (6 inch) with 6 mm (¼ inch) rubber lagged option
- Spherical self aligning pillow block bearings
- Fast installation, easy maintenance

Application

Milltronics bend pulleys provide constant belt contact for use with Siemens speed sensors. Designed for use in rugged operating environments common to mining, aggregates, cement, minerals, and other process industries. They ensure concentric speed sensor rotation to reduce pre-mature bearing failure. The use of a bend pulley driven speed sensor ensures no modification is required on any existing conveyor shaft. Options include stainless steel construction, epoxy painting, polymer bearings, self cleaning style, and lagged style.

Technical specifications

Milltronics Bend Pulleys

| | |
|---------------------------------|--|
| Typical application | Mining, aggregates, cement, minerals, and other process industries |
| Medium conditions | |
| Operating temperature | -40 ... +110 °C (-40 ... +230 °F) |
| Shaft material | Mild steel 316 (1.44) stainless steel, option |
| Pulleys | |
| Self cleaning rubber disc style | 114 mm (4.5 inch) diameter |
| Steel drum | 152 mm (6 inch) diameter |
| Steel drum | 152 mm (6 inch) diameter with 6 mm (¼ inch) rubber lagged option |
| Bearings | <ul style="list-style-type: none"> • Heavy-duty self aligning pillow block bearings, standard • Polymer self aligning pillow block bearings option |
| Belt speed | |
| Self cleaning | 1.79 m/s (350 fpm) max. |
| Drum | 3 m/s (600 fpm) |
| Approvals | CE, C-TICK |

| Selection and Ordering data | Order No. | Order No. |
|--|---|---|
| <p>Milltronics Bend Pulley, 4.5 inch and 6 inch diameter Return belt driven pulley provides rotation for shaft-driven speed sensors. 4.5 inch size is self-cleaning.</p> <p>Size 4.5 inch diameter self cleaning¹⁾ 6 inch diameter</p> <p>Belt width and 'A' dimension 18 inch, A=27 inch (686 mm), 20 inch, A=29 inch (737 mm) 24 inch, A=33 inch (838 mm) 30 inch, A=39 inch (991 mm) 36 inch, A=45 inch (1143 mm) 42 inch, A=51 inch (1295 mm) 48 inch, A=57 inch (1448 mm) 54 inch, A=63 inch (1600 mm) 60 inch, A=69 inch (1753 mm) 66 inch, A=75 inch (1905 mm) 500 mm, A=29 ... 31.5 inch (740 ... 800 mm) 650 mm, A=35 ... 37.6 inch (890 ... 954 mm) 800 mm, A=41 ... 43.5 inch (1040 ... 1104 mm) 800 mm, A=43 ... 45.4 inch (1090 ... 1154 mm) 1000 mm, A=48.8 ... 51.3 inch (1240 ... 1304 mm) 1200 mm, A=56.6 ... 59.2 inch (1440 ... 1504 mm) 1400 mm, A=64.6 ... 67.1 inch (1640 ... 1704 mm) 1450 mm, A=66.5 ... 69.0 inch (1690 ... 1754 mm) 1600 mm, A=72.4 ... 74.9 inch (1840 ... 1904 mm)</p> <p>Finish Standard, polyester painted mild steel²⁾ 316 (1.4401) stainless steel³⁾ 316 (1.4401) stainless steel⁴⁾ Epoxy painted⁵⁾ Epoxy painted, with corrosion resistant bearings⁵⁾</p> <p>Bearings Imperial size Metric size No bearings</p> <p>Operating Instructions English Note: The Operating Instructions should be ordered as a separate item on the order. This device is shipped with the Siemens Milltronics manual CD containing the complete Operating Instructions library.</p> | <p>C) 7MH7170- 0 1 2 A B C E G H K L M N P Q R S T U V W A B C D E 0 1 2</p> | <p>C) 7MH7171- 0 3 A B C E G H K L M N P Q R S T U V W A B C 0 1 2</p> |
| <p>Milltronics Bend Pulley, 6 inch diameter with 1/4 inch lagging Return belt driven pulley provides rotation for shaft-driven speed sensors The lagging offers self-cleaning advantages and ensures positive rotation.</p> <p>Size 6 inch diameter with 1/4 inch lagging</p> <p>Belt width and 'A' dimension 18 inch, A=27 inch (686 mm), 20 inch, A=29 inch (737 mm) 24 inch, A=33 inch (838 mm) 30 inch, A=39 inch (991 mm) 36 inch, A=45 inch (1143 mm) 42 inch, A=51 inch (1295 mm) 48 inch, A=57 inch (1448 mm) 54 inch, A=63 inch (1600 mm) 60 inch, A=69 inch (1753 mm) 66 inch, A=75 inch (1905 mm) 500 mm, A=29 ... 31.5 inch (740 ... 800 mm) 650 mm, A=35 ... 37.6 inch (890 ... 954 mm) 800 mm, A=41 ... 43.5 inch (1040 ... 1104 mm) 800 mm, A=43 ... 45.4 inch (1090 ... 1154 mm) 1000 mm, A=48.8 ... 51.3 inch (1240 ... 1304 mm) 1200 mm, A=56.6 ... 59.2 inch (1440 ... 1504 mm) 1400 mm, A=64.6 ... 67.1 inch (1640 ... 1704 mm) 1450 mm, A=66.5 ... 69.0 inch (1754 mm) 1600 mm, A=72.4 ... 74.9 inch (1840 ... 1904 mm)</p> <p>Finish Standard, polyester painted mild steel 316 (1.4401) stainless steel 316 (1.4401) stainless steel with corrosion resistant bearings</p> <p>Bearings Imperial size Metric size No bearings</p> <p>Operating Instructions English Note: The Operating Instructions should be ordered as a separate item on the order. This device is shipped with the Siemens Milltronics manual CD containing the complete Operating Instructions library.</p> | <p>C) 7ML1998-5DE02</p> | <p>C) 7ML1998-5DE02</p> |

1) Available with belt width and 'A' dimension options A to H and N to V only
 2) Not painted with 4.5" diameter model
 3) 316 (1.4401) stainless steel shaft on 4.5 inch diameter models only
 4) With corrosion resistant bearings, 316 (1.4401) stainless steel shaft on 4.5 inch diameter models only
 5) For 6 inch diameter models only

C) Subject to export regulations AL: N, ECCN: EAR99.



Belt Scales

Speed Sensors

Milltronics Bend Pulley

Selection and Ordering data

Order No.

Milltronics Bend Pulley, 8 inch diameter C) **7MH7187-**
Belt driven pulley for WS Series speed sensors.

Size

8 inch diameter

4

Belt width and 'A' dimension

48 inch, A=57 ... 59.5 inch (1447.8 ... 1511 mm)

54 inch, A=63 ... 65.5 inch (1600.2 ... 1663 mm)

60 inch, A=69 ... 71.5 inch (1752.6 ... 1816 mm)

66 inch, A=75 ... 77.5 inch (1905 ... 1968 mm)

72 inch, A=81 ... 83.5 inch (2057 ... 2121 mm)

78 inch, A=87 ... 89.5 inch (2210 ... 2273 mm)

84 inch, A=93 ... 95.5 inch (2362 ... 2426 mm)

90 inch, A=99 ... 101.5 inch (2515 ... 2578 mm)

96 inch, A=105 ... 107.5 inch (2667 ... 2731 mm)

1200 mm, A=56.6 ... 59.2 inch (1440 ... 1504 mm)

1400 mm, A=64.6 ... 67.1 inch (1640 ... 1704 mm)

1450 mm, A=66.5 ... 69.0 inch (1690 ... 1754 mm)

1600 mm, A=72.4 ... 74.9 inch (1840 ... 1904 mm)

1800 mm, A=80.3 ... 82.8 inch (2040 ... 2104 mm)

2000 mm, A=88.2 ... 90.7 inch (2240 ... 2304 mm)

2200 mm, A=96.1 ... 98.6 inch (2440 ... 2504 mm)

2400 mm, A=103.9 ... 106.4 inch (2640 ... 2704 mm)

2500 mm, A=107.9 ... 110.4 inch (2740 ... 2804 mm)

Order No.

Milltronics Bend Pulley, 8 inch diameter with 1/4 inch lagging C) **7MH7188-**
Belt driven pulley for WS Series speed sensors. The lagging offers self-cleaning advantages and ensures positive rotation.

Size

8 inch diameter with 1/4 inch lagging

5

Belt width and 'A' dimension

48 inch, A=57 ... 59.5 inch (1447.8 ... 1511 mm)

54 inch, A=63 ... 65.5 inch (1600.2 ... 1663 mm)

60 inch, A=69 ... 71.5 inch (1752.6 ... 1816 mm)

66 inch, A=75 ... 77.5 inch (1905 ... 1968 mm)

72 inch, A=81 ... 83.5 inch (2057 ... 2121 mm)

78 inch, A=87 ... 89.5 inch (2210 ... 2273 mm)

84 inch, A=93 ... 95.5 inch (2362 ... 2426 mm)

90 inch, A=99 ... 101.5 inch (2515 ... 2578 mm)

96 inch, A=105 ... 107.5 inch (2667 ... 2731 mm)

1200 mm, A=56.6 ... 59.2 inch (1440 ... 1504 mm)

1400 mm, A=64.6 ... 67.1 inch (1640 ... 1704 mm)

1450 mm, A=66.5 ... 69.0 inch (1690 ... 1754 mm)

1600 mm, A=72.4 ... 74.9 inch (1840 ... 1904 mm)

1800 mm, A=80.3 ... 82.8 inch (2040 ... 2104 mm)

2000 mm, A=88.2 ... 90.7 inch (2240 ... 2304 mm)

2200 mm, A=96.1 ... 98.6 inch (2440 ... 2504 mm)

2400 mm, A=103.9 ... 106.4 inch (2640 ... 2704 mm)

2500 mm, A=107.9 ... 110.4 inch (2740 ... 2804 mm)

4

Dimensional drawings

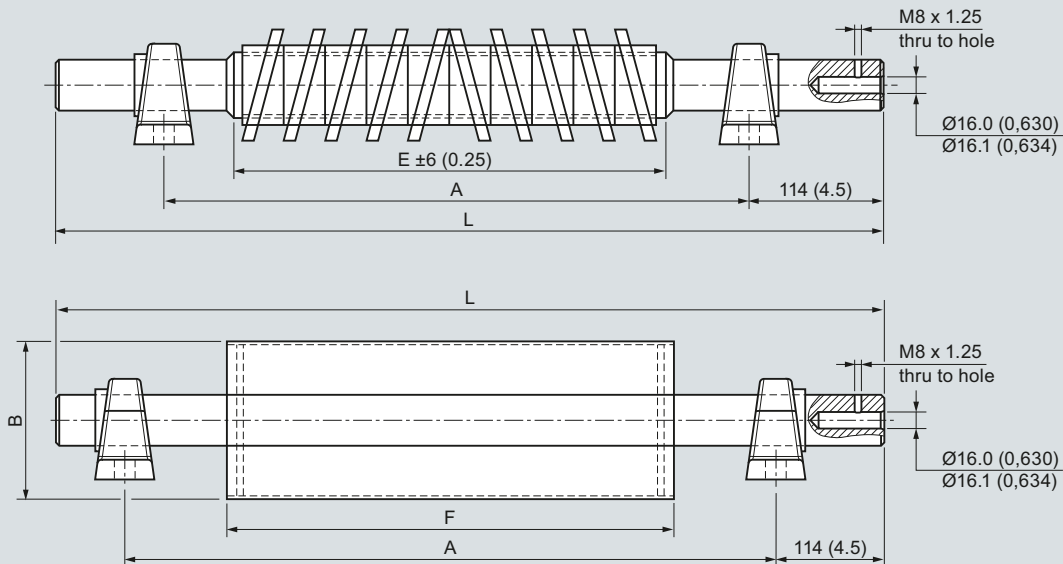

| Version | B |
|----------|--------------------------|
| Standard | Ø152 (6.0) or 203 (8.0) |
| Lagged | Ø165 (6.5) or 216 (8.50) |

| Belt size | E | A | L | F |
|------------------|---------------------|---------------------------------------|----------------------|----------------------|
| 18 inch, 20 inch | 18 inch (460 mm) | 27 inch (686 mm), 29 inch (737 mm) | 34.5 inch (876 mm) | 20 inch (508 mm) |
| 24 inch | 24 inch (610 mm) | 33 inch (838 mm) | 40.5 inch (1029 mm) | 26 inch (660 mm) |
| 30 inch | 30 inch (762 mm) | 39 inch (991 mm) | 46.5 inch (1181 mm) | 32 inch (812 mm) |
| 36 inch | 36 inch (915 mm) | 45 inch (1143 mm) | 52.5 inch (1334 mm) | 38 inch (965 mm) |
| 42 inch | 42 inch (1066 mm) | 51 inch (1295 mm) | 58.5 inch (1486 mm) | 44 inch (1118 mm) |
| 48 inch | 48 inch (1220 mm) | 57 inch (1448 mm) | 64.5 inch (1638 mm) | 51 inch (1296 mm) |
| 54 inch | | 63 inch (1600 mm) | 70.5 inch (1791 mm) | 57 inch (1448 mm) |
| 60 inch | | 69 inch (1753 mm) | 76.5 inch (1943 mm) | 63 inch (1600 mm) |
| 66 inch | | 75 inch (1905 mm) | 82.5 inch (2096 mm) | 69 inch (1752 mm) |
| 500 mm | 500 mm (19.7 inch) | 737 mm (29 inch) | 927 mm (36.5 inch) | 551 mm (21.7 inch) |
| 650 mm | 650 mm (25.6 inch) | 890 mm (35 inch) | 1080 mm (42.5 inch) | 701 mm (27.6 inch) |
| 800 mm | 800 mm (31.5 inch) | 1040 mm (41 inch) | 1232 mm (48.5 inch) | 851 mm (33.5 inch) |
| 800 mm | 800 mm (31.5 inch) | 1090 mm (43 inch) | 1283 mm (50.5 inch) | 851 mm (33.5 inch) |
| 1000 mm | 1000 mm (39.4 inch) | 1240 mm (48.8 inch) | 1430 mm (56.3 inch) | 1052 mm (41.4 inch) |
| 1200 mm | 1200 mm (47.2 inch) | 1540 mm (60.6 inch) | 1730 mm (68.1 inch) | 1275 mm (50.2 inch) |
| 1400 mm | | 1650 mm (65 inch) | 1842 mm (72.5 inch) | 1476 mm (58.1 inch) |
| 1450 mm | | 1702 mm (67 inch) | 1892 mm (74.5 inch) | 1527 mm (60.1 inch) |
| 1600 mm | | 1940 mm (76.4 inch) | 2131 mm (83.9 inch) | 1676 mm (66 inch) |
| 1800 mm | | 80.3 inch (2040 mm) | 87.8 inch (2230 mm) | 73.8 inch (1875 mm) |
| 2000 mm | | 88.2 inch (2240 mm) | 95.7 inch (2430 mm) | 81.7 inch (2075 mm) |
| 2200 mm | | 96.1 inch (2440 mm) | 103.5 inch (2630 mm) | 89.6 inch (2275 mm) |
| 2400 mm | | 103.9 inch (2640 mm) | 111.9 inch (2830 mm) | 97.4 inch (2475 mm) |
| 2500 mm | | 107.9 inch (2740 mm) | 115.4 inch (2930 mm) | 101.4 inch (2575 mm) |

Bend pulley, dimensions in inch (mm) unless otherwise indicated

Belt Scales

Belt Scales Accessories

Milltronics MWL Weight Lifter

Overview



Milltronics MWL weight lifter is a mechanical calibration weight lifter for MBS, MCS, MSI, MMI, and MUS belt scales.

Benefits

- Safe and easy application of belt scale reference weights with the operator remaining external to the conveyor
- Modular construction, easily adaptable to different conveyor widths
- Low profile allowing easy fit into belt conveyor
- Easy to install and apply
- Easy to store drive handle that can be applied to left or right side of MWL
- Security pin used to ensure safe storage of weight
- Can be used with new and existing applications

Application

Milltronics MWL mechanically raises and lowers the static weights and then stores the weights securely above the belt scale calibration arms, and allows the operator to lower and apply them safely without having to lean into the conveyor. The MWL is manually operated, and uses a high mechanical advantage to enable weights up to 340 kg (750 lb) to be applied with very limited effort. The crank handle uses twelve rotations for full range of motion, and can be removed and stored for safety with the locking ball-pin which secures the MWL when it is not in use.

Two lifting arms support a base-bar weight above the calibration (test) weight brackets of the belt scale: either flat bar or round bar style calibration weights are applicable. Locating notches in the base-bar weight engage the calibration weights securely on the lifting arms in the stored position, and the gear drive locks the lifting arms in place.

Installation is easy, just four bolt holes to drill after locating the MWL gear modules (LH and RH) on the conveyor with respect to the belt scale. After running the MWL empty to ensure proper alignment, and then tightening mounting bolts, you are ready for the loading of the calibration weights. This is the last time that they will have to be lifted by hand.

The motorized option allows for local or remote calibration of belt scales. Proximity sensors mounted to the MWL provide indication of storage or application of the test weight(s). The optional control panel features local control and indication of calibration as well as interfaces for remote calibration through a control system.

Technical specifications

| Milltronics MWL weight lifter | |
|--|---|
| Mode of operation | |
| Principle of operation | Mechanical gear drive |
| Typical application | Belt scale calibration |
| Medium conditions | |
| Max. ambient temperature | 75 °C (167 °F) |
| Belt design | |
| Belt width | <ul style="list-style-type: none"> • MBS: up to 1000 mm (42 inch) CEMA width • MCS: up to 1600 mm (60 inch) CEMA width • MUS-STD standard duty: up to 1000 mm (42 inch) CEMA width • MUS-HD heavy-duty: up to 1600 mm (60 inch) CEMA width • MSI: 18 ... 96 inch CEMA belt width |
| Idlers | |
| Idler spacing | 20° or more troughed idlers |
| Calibration weight capacity | |
| Up to 340 kg (750 lb) | |
| Crank arm | |
| Mechanical advantage | 20:1 |
| Number of revolutions required for raising or lowering | 12 |
| Motorized (option) | |
| Motor -0.75 hp (0.55 kw) IP55, integral 24 V DC brake, insulation class F, 220 ... 240/380 ... 460 V AC 3 pH 50/60 Hz or 575 V AC 3 pH 60 Hz | |
| Controller panel (option) | |
| 208 ... 240, 380 ... 420, 380 ... 480, 575 ... 600 V AC, Nema/Type 4, IP65 | |
| Mounting dimensions | |
| See reverse for standard and heavy-duty MUS, MBS, MCS, and MSI/MMI belt scales | |
| Approvals | |
| The MWL is in compliance with directive 98/37/EC, CE, C-TICK | |
| Motorized option | CE, C-TICK, CSA _{C/US} |

| Selection and Ordering data | Order No. | Order No. | |
|---|--|--|--|
| Milltronics MWL Weight Lifter A mechanical calibration weight lifter for MSI, MMI, MBS, MCS, and MUS belt scale ¹⁾ For use with MSI, ensure MSI fabrication option 4 1 is selected. | C) 7MH7218- | C) 7MH7218- | |
| Actuation Manually Motorized 220 ... 240/380 ... 460 V AC 3 pH 50/60 Hz ²⁾ Motorized 575 V AC 3 pH 60 Hz ²⁾ | 1 2 3 | Milltronics MWL Weight Lifter A mechanical calibration weight lifter for MSI, MMI, MBS, MCS, and MUS belt scale ¹⁾ For use with MSI, ensure MSI fabrication option 4 1 is selected. | |
| Belt Width and 'A' dimension 18 inch, 'A' =27 inch (686 mm) 19 inch, 'A' =28 inch (711 mm) 20 inch, 'A' =29 inch (737 mm) 21 inch, 'A' =30 inch (762 mm) 22 inch, 'A' =31 inch (787 mm) 23 inch, 'A' =32 inch (813 mm) 24 inch, 'A' =33 inch (838 mm) 25 inch, 'A' =34 inch (864 mm) 26 inch, 'A' =35 inch (889 mm) 27 inch, 'A' =36 inch (914 mm) 28 inch, 'A' =37 inch (940 mm) 29 inch, 'A' =38 inch (965 mm) 30 inch, 'A' =39 inch (991 mm) 31 inch, 'A' =40 inch (1016 mm) 32 inch, 'A' =41 inch (1041 mm) 33 inch, 'A' =42 inch (1067 mm) 34 inch, 'A' =43 inch (1092 mm) 35 inch, 'A' =44 inch (1118 mm) 36 inch, 'A' =45 inch (1143 mm) 37 inch, 'A' =46 inch (1168 mm) 38 inch, 'A' =47 inch (1194 mm) 39 inch, 'A' =48 inch (1219 mm) 40 inch, 'A' =49 inch (1245 mm) 41 inch, 'A' =50 inch (1270 mm) 42 inch, 'A' =51 inch (1295 mm) 43 inch, 'A' =52 inch (1321 mm) 44 inch, 'A' =53 inch (1346 mm) 45 inch, 'A' =54 inch (1372 mm) 46 inch, 'A' =55 inch (1397 mm) 47 inch, 'A' =56 inch (1422 mm) 48 inch, 'A' =57 inch (1448 mm) 49 inch, 'A' =58 inch (1473 mm) 50 inch, 'A' =59 inch (1499 mm) 51 inch, 'A' =60 inch (1524 mm) 52 inch, 'A' =61 inch (1549 mm) 53 inch, 'A' =62 inch (1575 mm) 54 inch, 'A' =63 inch (1600 mm) 55 inch, 'A' =64 inch (1626 mm) 56 inch, 'A' =65 inch (1651 mm) 57 inch, 'A' =66 inch (1676 mm) 58 inch, 'A' =67 inch (1702 mm) 59 inch, 'A' =68 inch (1727 mm) 60 inch, 'A' =69 inch (1753 mm) 61 inch, 'A' =70 inch (1778 mm) 62 inch, 'A' =71 inch (1803 mm) | AA AB AC AD AE AF AG AH AJ AK AL AM AN AP AQ AR AS AT AU AV AW BA BB BC BD BE BF BG BH BJ BK BL BM BN BP BQ BR BS BT BU BV BW CA CB CC | 63 inch, 'A' =72 inch (1829 mm) 64 inch, 'A' =73 inch (1854 mm) 65 inch, 'A' =74 inch (1880 mm) 66 inch, 'A' =75 inch (1905 mm) 67 inch, 'A' =76 inch (1930 mm) 68 inch, 'A' =77 inch (1956 mm) 69 inch, 'A' =78 inch (1981 mm) 70 inch, 'A' =79 inch (2007 mm) 71 inch, 'A' =80 inch (2032 mm) 72 inch, 'A' =81 inch (2057 mm) 73 inch, 'A' =82 inch (2083 mm) 74 inch, 'A' =83 inch (2108 mm) 75 inch, 'A' =84 inch (2134 mm) 76 inch, 'A' =85 inch (2159 mm) 77 inch, 'A' =86 inch (2184 mm) 78 inch, 'A' =87 inch (2210 mm) 79 inch, 'A' =88 inch (2235 mm) 80 inch, 'A' =89 inch (2261 mm) 81 inch, 'A' =90 inch (2286 mm) 82 inch, 'A' =91 inch (2311 mm) 83 inch, 'A' =92 inch (2337 mm) 84 inch, 'A' =93 inch (2362 mm) 85 inch, 'A' =94 inch (2388 mm) 86 inch, 'A' =95 inch (2413 mm) 87 inch, 'A' =96 inch (2438 mm) 88 inch, 'A' =97 inch (2464 mm) 89 inch, 'A' =98 inch (2489 mm) 90 inch, 'A' =99 inch (2515 mm) 91 inch, 'A' =100 inch (2540 mm) 92 inch, 'A' =101 inch (2565 mm) 93 inch, 'A' =102 inch (2591 mm) 94 inch, 'A' =103 inch (2616 mm) 95 inch, 'A' =104 inch (2642 mm) 96 inch, 'A' =105 inch (2667 mm) No width parts ³⁾ | CD CE CF CG CH CJ CK CL CM CN CP CQ CR CS CT CU CV CW DA DB DC DD DE DF DG DH DJ DK DL DM DN DP DQ DR XX |
| | | Weight type None For use with flat bar weights (weights not included) <u>Width's based on belt width</u> 3 inch integrated round bar weight (18 ... 29 inch, 15.9 ... 22.7 kg) 3 inch integrated round bar weight (30 ... 41 inch, 26.8 ... 33.6 kg) 3 inch integrated round bar weight (42 ... 53 inch, 37.7 ... 44.5 kg) 3 inch integrated round bar weight (54 ... 65 inch, 48.6 ... 58.6 kg) 3 inch integrated round bar weight (66 ... 77 inch, 59.5 ... 69.5 kg) 3 inch integrated round bar weight (78 ... 89 inch, 70.4 ... 80.4 kg) 3 inch integrated round bar weight (90 ... 96 inch, 81.3 ... 86.8 kg) 4 inch integrated round bar weight (18 ... 29 inch, 23.3 ... 34.3 kg) | 00 11 31 32 33 34 35 36 37 41 |

Belt Scales

Belt Scales Accessories

Milltronics MWL Weight Lifter

Selection and Ordering data (continued)

| Selection and Ordering data (continued) | Order No. |
|---|--------------------|
| Milltronics MWL Weight Lifter A mechanical calibration weight lifter for MSI, MMI, MBS, MCS, and MUS belt scales ¹⁾ For use with MSI, ensure MSI fabrication option 4 1 is selected. | C) 7MH7218- |
| 4 inch integrated round bar weight (30 ... 41 inch, 42.7 ... 53.7 kg) | 4 2 |
| 4 inch integrated round bar weight (42 ... 53 inch, 62.1 ... 73.1 kg) | 4 3 |
| 4 inch integrated round bar weight (54 ... 65 inch, 81.5 ... 99.3 kg) | 4 4 |
| 4 inch integrated round bar weight (66 ... 77 inch, 100.9 ... 118.6 kg) | 4 5 |
| 4 inch integrated round bar weight (78 ... 89 inch, 120.3 ... 138.0 kg) | 4 6 |
| 4 inch integrated round bar weight (90 ... 96 inch, 139.6 ... 149.3 kg) | 4 7 |
| 5 inch integrated round bar weight (18 ... 29 inch, 32.9 ... 49.3 kg) | 5 1 |
| 5 inch integrated round bar weight (30 ... 41 inch, 63.2 ... 79.6 kg) | 5 2 |
| 5 inch integrated round bar weight (42 ... 53 inch, 93.5 ... 109.9 kg) | 5 3 |
| 5 inch integrated round bar weight (54 ... 65 inch, 123.7 ... 151.5 kg) | 5 4 |
| 5 inch integrated round bar weight (66 ... 77 inch, 154.0 ... 181.8 kg) | 5 5 |
| 5 inch integrated round bar weight (78 ... 89 inch, 184.3 ... 212.1 kg) | 5 6 |
| 5 inch integrated round bar weight (90 ... 96 inch, 214.6 ... 229.7 kg) | 5 7 |
| 6 inch integrated round bar weight (18 ... 29 inch, 44.5 ... 67.6 kg) | 6 1 |
| 6 inch integrated round bar weight (30 ... 41 inch, 88.2 ... 111.2 kg) | 6 2 |
| 6 inch integrated round bar weight (42 ... 53 inch, 131.8 ... 154.8 kg) | 6 3 |
| 6 inch integrated round bar weight (54 ... 65 inch, 175.4 ... 215.3 kg) | 6 4 |
| 6 inch integrated round bar weight (66 ... 77 inch, 219.0 ... 258.9 kg) | 6 5 |
| 6 inch integrated round bar weight (78 ... 89 inch, 262.6 ... 302.5 kg) | 6 6 |
| 6 inch integrated round bar weight (90 ... 96 inch, 306.2 ... 328.0 kg) | 6 7 |
| Fabrication | |
| Standard, polyester painted mild steel | 1 |
| Other materials available upon request. | |
| Electro galvanized mild steel | 2 |
| Further designs | Order Code |
| Please add "-Z" to Order No. and specify Order code(s). | |
| Stainless Steel tag [69 x 38 mm (2.7 x 1.5 inch)], Measuring-point number / identification (max 16 characters), specify in plain text. | Y15 |
| Manufacturer's Test Certificate: According to EN 10204-2.2 | C11 |
| Right side mounted motor (facing the MWL's weight's back) | M30 |
| Left side mounted motor (facing the MWL's weight's back) | M31 |
| Motorized MWL control panel: local or remote interface with up, down button/indicator, NEMA/Type 4, IP65, 15.75 x 19.68 x 8.27 inch (400 x 500 x 210 mm) | A10 |

| Selection and Ordering data (continued) | Order No. |
|---|-------------------------|
| Milltronics MWL Weight Lifter A mechanical calibration weight lifter for MSI, MMI, MBS, MCS, and MUS belt scales ¹⁾ For use with MSI, ensure MSI fabrication option 4 1 is selected. | C) 7MH7218- |
| Operating Instructions | |
| • English | C) 7ML1998-5CR03 |
| • French | C) 7ML1998-5CR12 |
| • Spanish | C) 7ML1998-5CR22 |
| • German Note: The Operating Instructions should be ordered as a separate line on the order. | C) 7ML1998-5CR32 |
| Spare parts | |
| MWL handle shaft extension, 3.75 inch (95 mm) | 7MH726-1AM |
| MWL module LH unit | C) 7MH723-1GU |
| MWL module RH unit | C) 7MH723-1GV |
| MWL handle | C) 7MH723-1GX |
| MWL retrofit kit (for for Milltronics MSI, MMI belt scales) | 7MH723-1FW |
| MWL retrofit kit galvanized (for for Milltronics MSI, MMI belt scales) | C) 7MH723-1JT |
| MWL retrofit kit (for for Milltronics MBS, MCS belt scales) | C) 7MH723-1HA |
| MWL handle shaft extension galvanized [3.75 inch (95 mm)] | 7MH723-1JS |
| MWL motorized control panel | 7MH723-1JV |
| MWL module LH unit galvanized | C) 7MH723-1HK |
| MWL module RH unit galvanized | C) 7MH723-1HL |
| MWL handle galvanized | C) 7MH723-1HM |
| Proximity switches for motorized MWL | 7MH723-1KH |
| Gearmotor 220 ... 240/380 ... 460 V AC 3 pH 50/60 Hz | 7MH723-1KJ |
| Gearmotor 575 V AC 3 pH 60 Hz | 7MH723-1KK |
| 1) One MWL is required for each scale (MMI-2 requires 2 MWL) | |
| 2) Select motor mounting, order code option M30 or M31 | |
| 3) Available with weight type option 00 only | |
| C) Subject to export regulations AL: N, ECCN: EAR99. | |

Dimensional drawings

MWL with MUS - STD Standard Duty Belt Scale

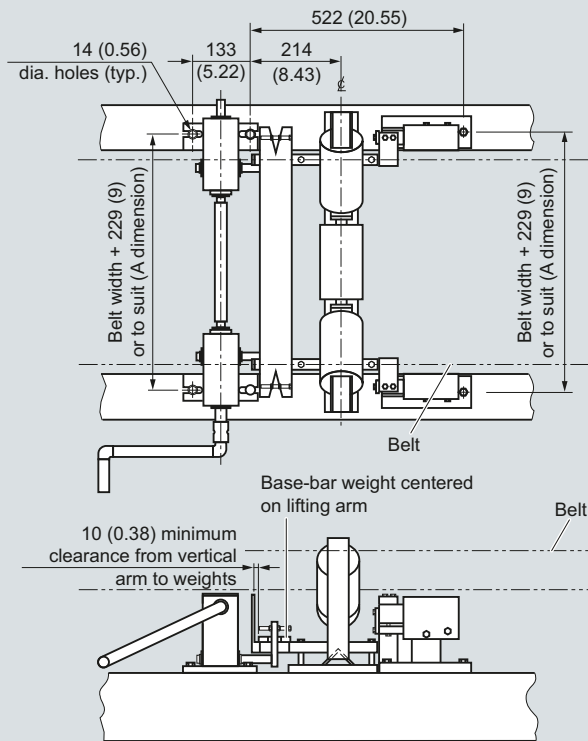

MWL with MUS - HD Heavy Duty Belt Scale

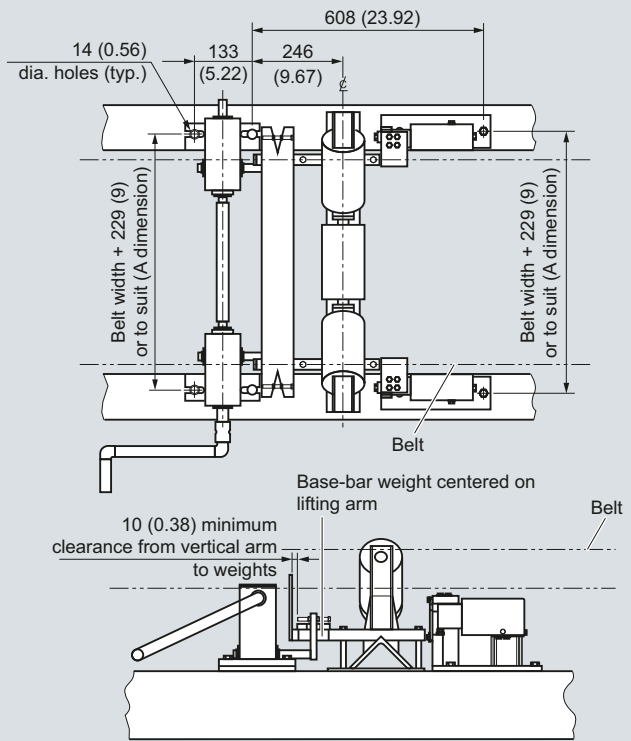

MWL with MBS Belt Scale

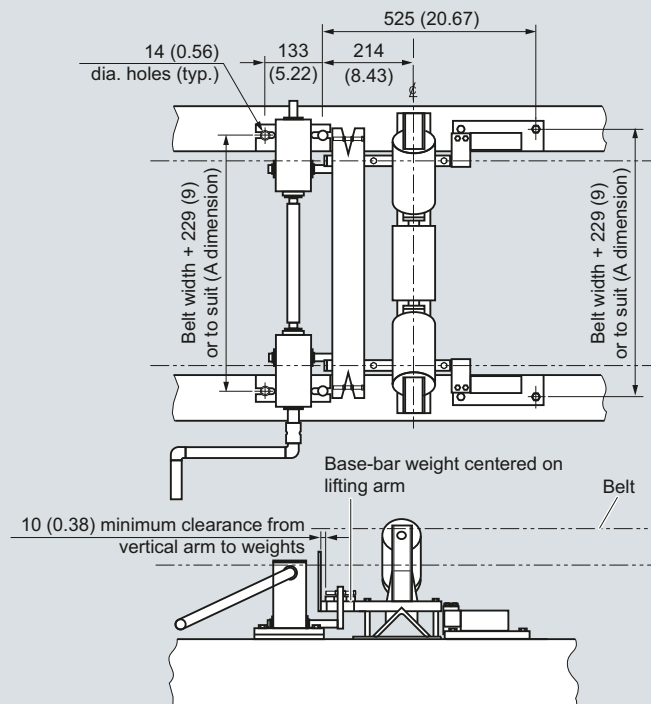

MWL dimensions in mm (inch)

Belt Scales

Belt Scales Accessories

Milltronics MWL Weight Lifter

Dimensional drawings (continued)

MWL with MCS belt scale

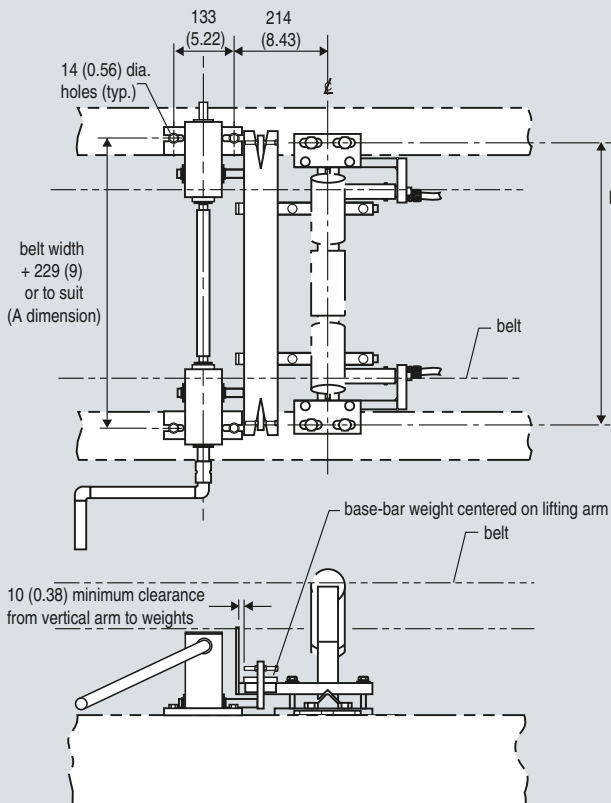

MWL with MSI/MMI belt scale

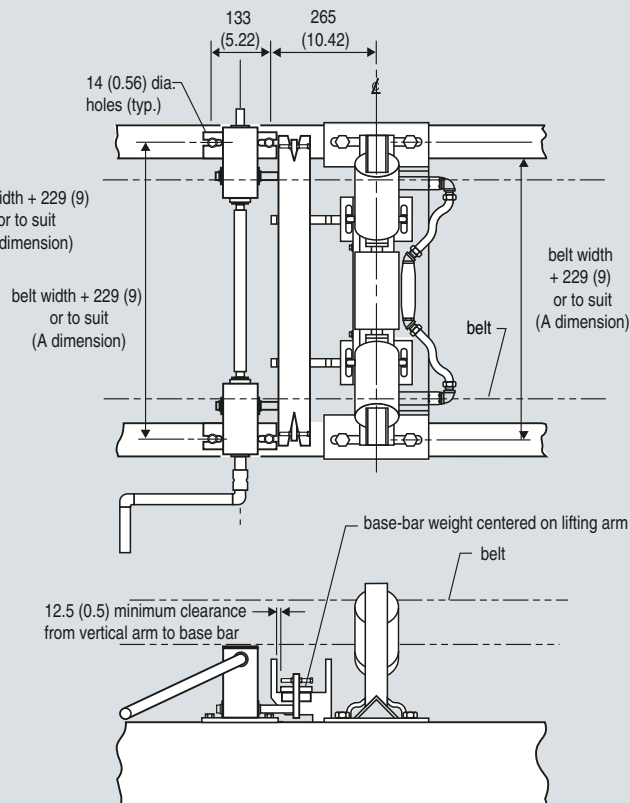

MWL electronic version

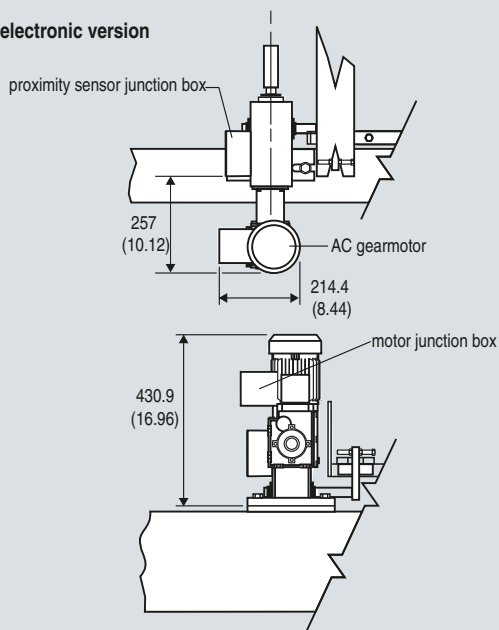

MWL dimensions in mm (inch)

4

| Selection and Ordering data | Order No. |
|--|-----------------|
| Milltronics flat bar calibration weights Designed for use with Milltronics belt scales. Length of bar weight is A dimension minus 3 inch (76 mm). Listed weight is an approximation. | 7MH7127- |
| Bar width, belt width and A dimension, weight | |
| 3 inch, 18 inch, A=27 inch (686 mm), 4.63 kg | 1 AA |
| 3 inch, 24 inch, A=33 inch (838 mm), 5.78 kg | 1 AG |
| 3 inch, 30 inch, A=39 inch (991 mm), 6.94 kg | 1 AN |
| 3 inch, 36 inch, A=45 inch (1143 mm), 8.10 kg | 1 AU |
| 3 inch, 42 inch, A=51 inch (1295 mm), 9.25 kg | 1 BD |
| 3 inch, 48 inch, A=57 inch (1448 mm), 10.41 kg | 1 BK |
| 3 inch, 54 inch, A=63 inch (1600 mm), 11.57 kg | 1 BR |
| 3 inch, 60 inch, A=69 inch (1753 mm), 12.73 kg | 1 CA |
| 3 inch, 66 inch, A=75 inch (1905 mm), 13.89 kg | 1 CG |
| 3 inch, 72 inch, A=81 inch (2057 mm), 15.05 kg | 1 CN |
| 3 inch, 78 inch, A=87 inch (2210 mm), 16.21 kg | 1 CU |
| 3 inch, 84 inch, A=93 inch (2362 mm), 17.37 kg | 1 DD |
| 3 inch, 90 inch, A=99 inch (2515 mm), 18.53 kg | 1 DK |
| 3 inch, 96 inch, A=105 inch (2667 mm), 19.69 kg | 1 DR |
| 4 inch, 18 inch, A=27 inch (686 mm), 6.17 kg | 2 AA |
| 4 inch, 24 inch, A=33 inch (838 mm), 7.71 kg | 2 AG |
| 4 inch, 30 inch, A=39 inch (991 mm), 9.26 kg | 2 AN |
| 4 inch, 36 inch, A=45 inch (1143 mm), 10.80 kg | 2 AU |
| 4 inch, 42 inch, A=51 inch (1295 mm), 12.34 kg | 2 BD |
| 4 inch, 48 inch, A=57 inch (1448 mm), 13.89 kg | 2 BK |
| 4 inch, 54 inch, A=63 inch (1600 mm), 15.42 kg | 2 BR |
| 4 inch, 60 inch, A=69 inch (1753 mm), 16.97 kg | 2 CA |
| 4 inch, 66 inch, A=75 inch (1905 mm), 18.52 kg | 2 CG |
| 4 inch, 72 inch, A=81 inch (2057 mm), 20.07 kg | 2 CN |
| 4 inch, 78 inch, A=87 inch (2210 mm), 21.62 kg | 2 CU |
| 4 inch, 84 inch, A=93 inch (2362 mm), 23.17 kg | 2 DD |
| 4 inch, 90 inch, A=99 inch (2515 mm), 24.72 kg | 2 DK |
| 4 inch, 96 inch, A=105 inch (2667 mm), 26.27 kg | 2 DR |
| Fabrication Standard, polyester painted mild steel | 1 |
| C) Subject to export regulations AL: N, ECCN: EAR99. | |

Belt Scales

Belt Scales Accessories

Milltronics Test Chains

Overview



Roller test chains are used for belt scale calibration when material tests are not practical. All test chains are bushed. Minimum length is 4 ft (1.2 m).

Benefits

- Heavy-duty design for rugged applications and long life
- Precision machined components for accurate calibration
- Bushed rollers to ensure rotation during calibration
- Alternative to material tests when they are not possible

Application

Milltronics calibration test chains provide simulated material flow on a conveyor belt for use with belt scale calibration. Designed for use in environments where material tests cannot be performed, test chains come in a variety of capacity options for use in any application. They ensure constant and uniform belt loading similar to material being conveyed, and can be stored on a storage reel for quick and easy application. The use of a calibration test chain ensures that production totals are guaranteed.

Technical specifications

Milltronics Test Chains

Mode of operation

| | |
|------------------------|---|
| Principle of operation | Rides on carrying side of belt to simulate material loading |
|------------------------|---|

Medium conditions

| | |
|--------------------------|----------------|
| Max. ambient temperature | 65 °C (150 °F) |
|--------------------------|----------------|

Design

| | |
|--------------------------------------|---|
| Belt loading to meet any application | 5 lb/ft (7.4 kg/m) ... 100 lb/ft (148.8 kg/m) |
|--------------------------------------|---|

Length

| |
|------------------------------|
| Made to suit conveyor design |
|------------------------------|

Idler

| |
|-----------------------------|
| Flat to 45° troughed idlers |
|-----------------------------|

Mounting

| |
|--|
| Connected to conveyor at start and end of chain at both sides for uniform loading. |
|--|

| |
|---|
| Storage and application with test chain storage reel. |
|---|

Approvals

| |
|------------|
| CE, C-TICK |
|------------|

| Selection and Ordering data | Order No. | Order No. |
|---|--------------------|--------------------|
| Milltronics test chains | C) 7MH7161- | C) 7MH7161- |
| Roller test chains are used for belt scale calibration when material tests are not practical. All test chains are bushed. Minimum length is 4 feet (1.2 m). | 0 ■ ■ ■ 0 | 0 ■ ■ ■ 0 |
| <u>5 lb/ft (7.4 kg/m), 6 inch pitch</u> | | |
| 4 ... 7 ft (1.2 ... 2.1 m) | AA 1 | FF 1 |
| 8 ... 11 ft (2.4 ... 3.4 m) | AA 2 | FF 2 |
| 12 ... 15 ft (3.7 ... 4.6 m) | AA 3 | FF 3 |
| 16 ... 19 ft (4.9 ... 5.8 m) | AA 4 | FF 4 |
| 20 ... 23 ft (6.1 ... 7.0 m) | AA 5 | FF 5 |
| 24 ... 27 ft (7.3 ... 8.2 m) | AA 6 | FF 6 |
| 28 ... 31 ft (8.5 ... 9.4 m) | AA 7 | FF 7 |
| 32 ... 35 ft (9.8 ... 10.7 m) | AA 8 | FF 8 |
| <u>7.5 lb/ft (11.2 kg/m), 6 inch pitch</u> | | |
| 4 ... 7 ft (1.2 ... 2.1 m) | BB 1 | GG 1 |
| 8 ... 11 ft (2.4 ... 3.4 m) | BB 2 | GG 2 |
| 12 ... 15 ft (3.7 ... 4.6 m) | BB 3 | GG 3 |
| 16 ... 19 ft (4.9 ... 5.8 m) | BB 4 | GG 4 |
| 20 ... 23 ft (6.1 ... 7.0 m) | BB 5 | GG 5 |
| 24 ... 27 ft (7.3 ... 8.2 m) | BB 6 | GG 6 |
| 28 ... 31 ft (8.5 ... 9.4 m) | BB 7 | GG 7 |
| 32 ... 35 ft (9.8 ... 10.7 m) | BB 8 | GG 8 |
| <u>10 lb/ft (14.9 kg/m), 4 inch pitch</u> | | |
| 4 ... 7 ft (1.2 ... 2.1 m) | CC 1 | HH 1 |
| 8 ... 11 ft (2.4 ... 3.4 m) | CC 2 | HH 2 |
| 12 ... 15 ft (3.7 ... 4.6 m) | CC 3 | HH 3 |
| 16 ... 19 ft (4.9 ... 5.8 m) | CC 4 | HH 4 |
| 20 ... 23 ft (6.1 ... 7.0 m) | CC 5 | HH 5 |
| 24 ... 27 ft (7.3 ... 8.2 m) | CC 6 | HH 6 |
| 28 ... 31 ft (8.5 ... 9.4 m) | CC 7 | HH 7 |
| 32 ... 35 ft (9.8 ... 10.7 m) | CC 8 | HH 8 |
| <u>15 lb/ft (22.3 kg/m), 4 inch pitch</u> | | |
| 4 ... 7 ft (1.2 ... 2.1 m) | DD 1 | JJ 1 |
| 8 ... 11 ft (2.4 ... 3.4 m) | DD 2 | JJ 2 |
| 12 ... 15 ft (3.7 ... 4.6 m) | DD 3 | JJ 3 |
| 16 ... 19 ft (4.9 ... 5.8 m) | DD 4 | JJ 4 |
| 20 ... 23 ft (6.1 ... 7.0 m) | DD 5 | JJ 5 |
| 24 ... 27 ft (7.3 ... 8.2 m) | DD 6 | JJ 6 |
| 28 ... 31 ft (8.5 ... 9.4 m) | DD 7 | JJ 7 |
| 32 ... 35 ft (9.8 ... 10.7 m) | DD 8 | JJ 8 |
| <u>20 lb/ft (29.8 kg/m), 4 inch pitch</u> | | |
| 4 ... 7 ft (1.2 ... 2.1 m) | EE 1 | KK 1 |
| 8 ... 11 ft (2.4 ... 3.4 m) | EE 2 | KK 2 |
| 12 ... 15 ft (3.7 ... 4.6 m) | EE 3 | KK 3 |
| 16 ... 19 ft (4.9 ... 5.8 m) | EE 4 | KK 4 |
| 20 ... 23 ft (6.1 ... 7.0 m) | EE 5 | KK 5 |
| 24 ... 27 ft (7.3 ... 8.2 m) | EE 6 | KK 6 |
| 28 ... 31 ft (8.5 ... 9.4 m) | EE 7 | KK 7 |
| 32 ... 35 ft (9.8 ... 10.7 m) | EE 8 | KK 8 |
| <u>25 lb/ft (37.2 kg/m), 4 inch pitch</u> | | |
| 4 ... 7 ft (1.2 ... 2.1 m) | | |
| 8 ... 11 ft (2.4 ... 3.4 m) | | |
| 12 ... 15 ft (3.7 ... 4.6 m) | | |
| 16 ... 19 ft (4.9 ... 5.8 m) | | |
| 20 ... 23 ft (6.1 ... 7.0 m) | | |
| 24 ... 27 ft (7.3 ... 8.2 m) | | |
| 28 ... 31 ft (8.5 ... 9.4 m) | | |
| 32 ... 35 ft (9.8 ... 10.7 m) | | |
| <u>30 lb/ft (44.6 kg/m), 4 inch pitch</u> | | |
| 4 ... 7 ft (1.2 ... 2.1 m) | | |
| 8 ... 11 ft (2.4 ... 3.4 m) | | |
| 12 ... 15 ft (3.7 ... 4.6 m) | | |
| 16 ... 19 ft (4.9 ... 5.8 m) | | |
| 20 ... 23 ft (6.1 ... 7.0 m) | | |
| 24 ... 27 ft (7.3 ... 8.2 m) | | |
| 28 ... 31 ft (8.5 ... 9.4 m) | | |
| 32 ... 35 ft (9.8 ... 10.7 m) | | |
| <u>35 lb/ft (52.1 kg/m), 4 inch pitch</u> | | |
| 4 ... 7 ft (1.2 ... 2.1 m) | | |
| 8 ... 11 ft (2.4 ... 3.4 m) | | |
| 12 ... 15 ft (3.7 ... 4.6 m) | | |
| 16 ... 19 ft (4.9 ... 5.8 m) | | |
| 20 ... 23 ft (6.1 ... 7.0 m) | | |
| 24 ... 27 ft (7.3 ... 8.2 m) | | |
| 28 ... 31 ft (8.5 ... 9.4 m) | | |
| 32 ... 35 ft (9.8 ... 10.7 m) | | |
| <u>40 lb/ft (59.5 kg/m), 4 inch pitch</u> | | |
| 4 ... 7 ft (1.2 ... 2.1 m) | | |
| 8 ... 11 ft (2.4 ... 3.4 m) | | |
| 12 ... 15 ft (3.7 ... 4.6 m) | | |
| 16 ... 19 ft (4.9 ... 5.8 m) | | |
| 20 ... 23 ft (6.1 ... 7.0 m) | | |
| 24 ... 27 ft (7.3 ... 8.2 m) | | |
| 28 ... 31 ft (8.5 ... 9.4 m) | | |
| 32 ... 35 ft (9.8 ... 10.7 m) | | |
| <u>45 lb/ft (67.0 kg/m), 4 inch pitch</u> | | |
| 4 ... 7 ft (1.2 ... 2.1 m) | | |
| 8 ... 11 ft (2.4 ... 3.4 m) | | |
| 12 ... 15 ft (3.7 ... 4.6 m) | | |
| 16 ... 19 ft (4.9 ... 5.8 m) | | |
| 20 ... 23 ft (6.1 ... 7.0 m) | | |
| 24 ... 27 ft (7.3 ... 8.2 m) | | |
| 28 ... 31 ft (8.5 ... 9.4 m) | | |
| 32 ... 35 ft (9.8 ... 10.7 m) | | |

Belt Scales

Belt Scales Accessories

Milltronics Test Chains

Selection and Ordering data (continued)

Milltronics test chains

Roller test chains are used for belt scale calibration when material tests are not practical. All test chains are bushed. Minimum length is 4 feet (1.2 m).

50 lb/ft (74.4 kg/m), 4 inch pitch

4 ... 7 ft (1.2 ... 2.1 m)
8 ... 11 ft (2.4 ... 3.4 m)
12 ... 15 ft (3.7 ... 4.6 m)
16 ... 19 ft (4.9 ... 5.8 m)
20 ... 23 ft (6.1 ... 7.0 m)
24 ... 27 ft (7.3 ... 8.2 m)
28 ... 31 ft (8.5 ... 9.4 m)
32 ... 35 ft (9.8 ... 10.7 m)

60 lb/ft (89.3 kg/m), 6 inch pitch

4 ... 7 ft (1.2 ... 2.1 m)
8 ... 11 ft (2.4 ... 3.4 m)
12 ... 15 ft (3.7 ... 4.6 m)
16 ... 19 ft (4.9 ... 5.8 m)
20 ... 23 ft (6.1 ... 7.0 m)
24 ... 27 ft (7.3 ... 8.2 m)
28 ... 31 ft (8.5 ... 9.4 m)
32 ... 35 ft (9.8 ... 10.7 m)

70 lb/ft (104.2 kg/m), 6 inch pitch

4 ... 7 ft (1.2 ... 2.1 m)
8 ... 11 ft (2.4 ... 3.4 m)
12 ... 15 ft (3.7 ... 4.6 m)
16 ... 19 ft (4.9 ... 5.8 m)
20 ... 23 ft (6.1 ... 7.0 m)
24 ... 27 ft (7.3 ... 8.2 m)
28 ... 31 ft (8.5 ... 9.4 m)
32 ... 35 ft (9.8 ... 10.7 m)

80 lb/ft (119.1 kg/m), 6 inch pitch

4 ... 7 ft (1.2 ... 2.1 m)
8 ... 11 ft (2.4 ... 3.4 m)
12 ... 15 ft (3.7 ... 4.6 m)
16 ... 19 ft (4.9 ... 5.8 m)
20 ... 23 ft (6.1 ... 7.0 m)
24 ... 27 ft (7.3 ... 8.2 m)
28 ... 31 ft (8.5 ... 9.4 m)
32 ... 35 ft (9.8 ... 10.7 m)

90 lb/ft (133.9 kg/m), 6 inch pitch

4 ... 7 ft (1.2 ... 2.1 m)
8 ... 11 ft (2.4 ... 3.4 m)
12 ... 15 ft (3.7 ... 4.6 m)
16 ... 19 ft (4.9 ... 5.8 m)
20 ... 23 ft (6.1 ... 7.0 m)
24 ... 27 ft (7.3 ... 8.2 m)
28 ... 31 ft (8.5 ... 9.4 m)
32 ... 35 ft (9.8 ... 10.7 m)

Order No.

C) 7MH7161-

0 0

LL 1
LL 2
LL 3
LL 4
LL 5
LL 6
LL 7
LL 8

NN 1
NN 2
NN 3
NN 4
NN 5
NN 6
NN 7
NN 8

PP 1
PP 2
PP 3
PP 4
PP 5
PP 6
PP 7
PP 8

QQ 1
QQ 2
QQ 3
QQ 4
QQ 5
QQ 6
QQ 7
QQ 8

RR 1
RR 2
RR 3
RR 4
RR 5
RR 6
RR 7
RR 8

Order No.

C) 7MH7161-

0 0

SS 1
SS 2
SS 3
SS 4
SS 5
SS 6
SS 7
SS 8

Order code

Y01

Order No.

7ML1998-5JD01

C) 7ML1998-5JD31

Milltronics test chains

Roller test chains are used for belt scale calibration when material tests are not practical. All test chains are bushed. Minimum length is 4 feet (1.2 m).

100 lb/ft (148.8 kg/m), 6 inch pitch

4 ... 7 ft (1.2 ... 2.1 m)
8 ... 11 ft (2.4 ... 3.4 m)
12 ... 15 ft (3.7 ... 4.6 m)
16 ... 19 ft (4.9 ... 5.8 m)
20 ... 23 ft (6.1 ... 7.0 m)
24 ... 27 ft (7.3 ... 8.2 m)
28 ... 31 ft (8.5 ... 9.4 m)
32 ... 35 ft (9.8 ... 10.7 m)

Further models

Please add "-Z" to Order No. and specify Order codes(s)

Total length

Enter the total length in plain text description:
Y01: Total length ... mm (must be equivalent to whole feet, e.g. 1 foot = 304.8 mm)

Operating Instructions

- English
- German

Note: The Operating Instructions should be ordered as a separate item on the order.

This device is shipped with the Siemens Milltronics manual CD containing the complete Operating Instructions library.

C) Subject to export regulations AL: N, ECCN: EAR99.

Dimensional drawings

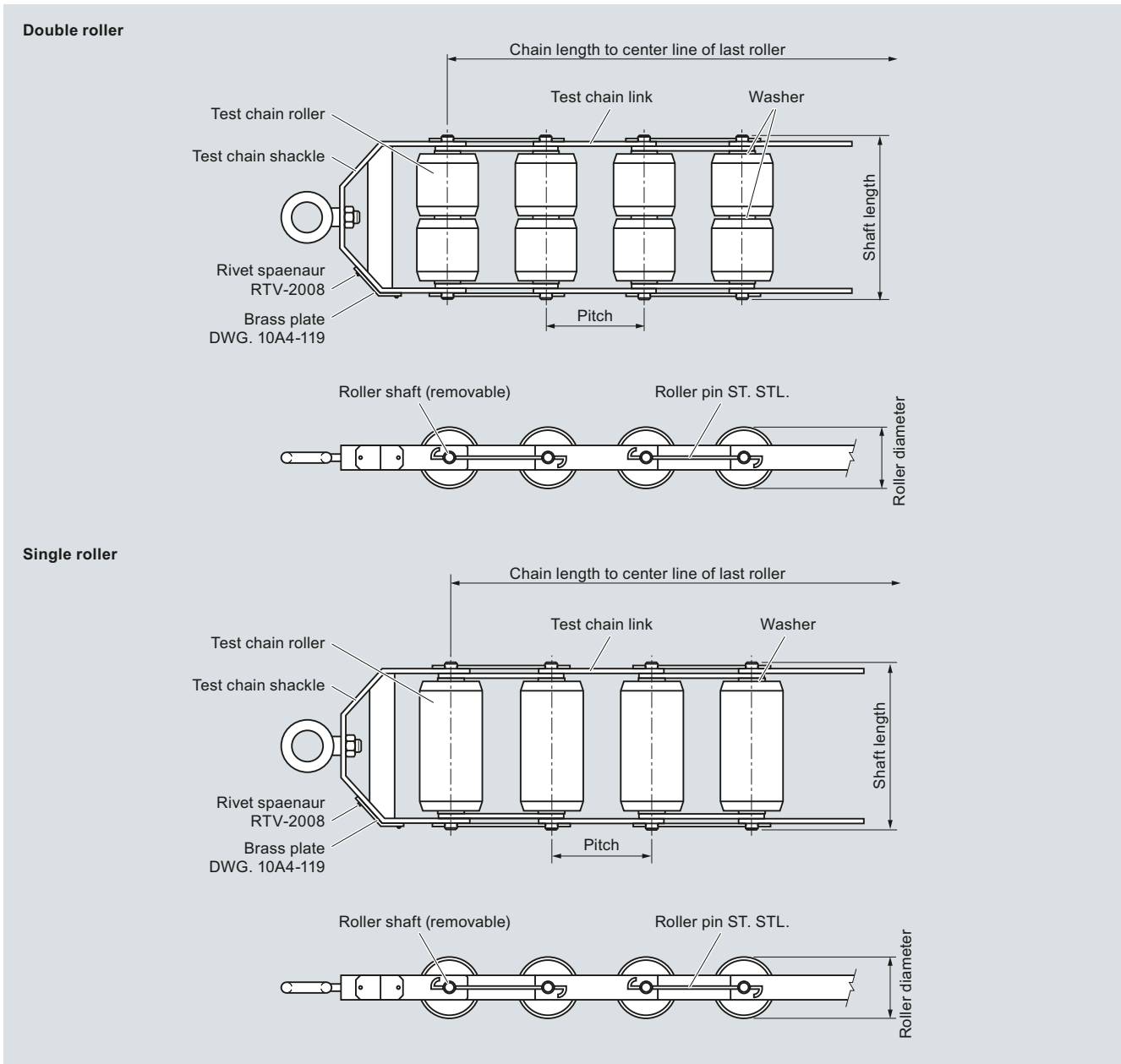

Milltronics test chain

Belt Scales

Belt Scales Accessories

Milltronics Test Chain Storage Reels

Overview

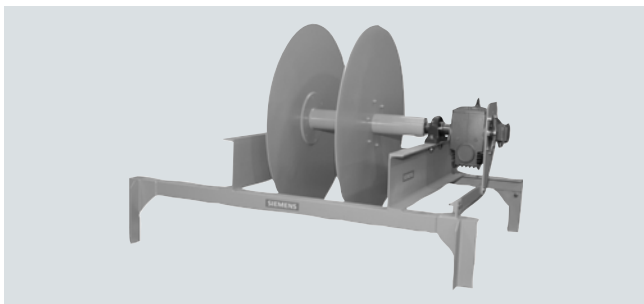

Test chain storage reels are used to store roller test chains. All test chain storage reels come with a geared brake motor.

Benefits

- Mounts to existing conveyor structure above belt
- Motorized application and retraction of test chains for calibration
- Fast and easy calibration

Application

Milltronics calibration test chain storage reels provide motorized application and retraction of test chains. Complete with an AC motorized storage reel, test chain reels ensure safe and quick use of calibration test chains. Designed for use in environments where material tests cannot be performed, test chain storage reels are available in any belt width to meet existing customer conveyor geometry. For linearity tests dual compartment reels are available for different chain weight calibration. Test chain storage reels have a brake integral to the motor ensuring that test chains do not un-reel during power outages or material running.

Technical specifications

| Milltronics Test Chain Storage Reels | |
|--------------------------------------|---|
| Medium conditions | |
| Operating temperature | -10 ... +60 °C (14 ... 140 °F) |
| Design | <ul style="list-style-type: none"> • Polyester painted structural steel • 10 mm (3/8 inch) galvanized rope provided for chain spooling • Self aligning pillow block bearings |
| Reel | Up to 1524 mm (60 inch) Chain application at 7 ... 10 RPM |
| Drive motor | TEFC, AC, three phase motor with shaft mounted helical bevel gear reducer |
| Approvals | CE, C-TICK |

Selection and Ordering data

Order No.

Milltronics test chain storage reels

C) 7MH7163-

Test chain storage reels are used to store roller test chains. All test chain storage reels come with a geared brake motor.

Compartment size

5 inches (127 mm) for chain sizes: 5 lb/ft (7.4 kg/m), 10 lb/ft (14.9 kg/m)

0

6 inches (152 mm) for chain sizes: 7.5 lb/ft (11.2 kg/m)

1

7 inches (178 mm) for chain sizes: 15 lb/ft (22.3 kg/m), 20 lb/ft (29.8 kg/m), 25 lb/ft (37.2 kg/m)

2

8 inches (203 mm) for chain sizes: 30 lb/ft (44.6 kg/m), 35 lb/ft (52.1 kg/m)

3

11 inches (279 mm) for chain sizes: 40 lb/ft (59.5 kg/m), 45 lb/ft (67.0 kg/m), 50 lb/ft (74.4 kg/m)

4

12 inches (305 mm) for chain sizes: 55 lb/ft (81.9 kg/m), 60 lb/ft (89.3 kg/m)

5

13 inches (330 mm) for chain sizes: 70 lb/ft (104.2 kg/m)

6

14 inches (356 mm) for chain sizes: 80 lb/ft (119.1 kg/m), 100 lb/ft (148.8 kg/m)

7

16 inches (406 mm) for chain sizes: 90 lb/ft (133.9 kg/m)

8

C dimension

25 inch (635 mm)

AA

26 inch (660 mm)

AB

27 inch (686 mm)

AC

28 inch (711 mm)

AD

29 inch (737 mm)

AE

30 inch (762 mm)

AF

31 inch (787 mm)

AG

32 inch (813 mm)

AH

33 inch (838 mm)

AJ

34 inch (864 mm)

AK

35 inch (889 mm)

AL

36 inch (914 mm)

AM

37 inch (940 mm)

AN

38 inch (965 mm)

AP

39 inch (991 mm)

AQ

40 inch (1016 mm)

AR

41 inch (1041 mm)

AS

42 inch (1067 mm)

AT

43 inch (1092 mm)

AU

44 inch (1118 mm)

AV

45 inch (1143 mm)

AW

46 inch (1168 mm)

BA

47 inch (1194 mm)

BB

48 inch (1219 mm)

BC

49 inch (1245 mm)

BD

50 inch (1270 mm)

BE

51 inch (1295 mm)

BF

52 inch (1321 mm)

BG

53 inch (1346 mm)

BH

54 inch (1372 mm)

BJ

55 inch (1397 mm)

BK

56 inch (1422 mm)

BL

57 inch (1448 mm)

BM

| Selection and Ordering data (continued) | Order No. | | Order No. |
|---|-----------------|---|-------------------------|
| Milltronics test chain storage reels | 7MH7163- | Milltronics test chain storage reels | 7MH7163- |
| Test chain storage reels are used to store roller test chains. All test chain storage reels come with a geared brake motor. | | Test chain storage reels are used to store roller test chains. All test chain storage reels come with a geared brake motor. | |
| 58 inch (1473 mm) | BN | 3 Phase motor voltage | |
| 59 inch (1499 mm) | BP | 230/460 V 60 Hz | 1 |
| 60 inch (1524 mm) | BQ | 200/400 V 50 Hz | 2 |
| 61 inch (1549 mm) | BR | 575 V 60 Hz | 3 |
| 62 inch (1575 mm) | BS | 190/380 V 50 Hz | 4 |
| 63 inch (1600 mm) | BT | 190/380 V 60 Hz | 5 |
| 64 inch (1626 mm) | BU | 220 V 60 Hz | 6 |
| 65 inch (1651 mm) | BV | 415 V 50 Hz | 7 |
| 66 inch (1676 mm) | BW | Reel type | |
| 67 inch (1702 mm) | CA | Single compartment for 1 calibration test chain | 0 |
| 68 inch (1727 mm) | CB | Double compartment for 2 calibration test chains | 1 |
| 69 inch (1753 mm) | CC | Reel diameter/motor mount location | |
| 70 inch (1778 mm) | CD | 36 inch (914 mm) / right hand access | 0 |
| 71 inch (1803 mm) | CE | 42 inch (1067 mm) / right hand access | 1 |
| 72 inch (1829 mm) | CF | 48 inch (1219 mm) / right hand access | 2 |
| 73 inch (1854 mm) | CG | 60 inch (1372 mm) / right hand access | 3 |
| 74 inch (1880 mm) | CH | 36 inch (914 mm) / left hand access | 4 |
| 75 inch (1905 mm) | CJ | 42 inch (1067 mm) / left hand access | 5 |
| 76 inch (1930 mm) | CK | 48 inch (1219 mm) / left hand access | 6 |
| 77 inch (1956 mm) | CL | 60 inch (1372 mm) / left hand access | 7 |
| 78 inch (1981 mm) | CM | Motor power | |
| 79 inch (2007 mm) | CN | 0.75 hp (0.56 kw) | A |
| 80 inch (2032 mm) | CP | 1 hp (0.75 kw) | B |
| 81 inch (2057 mm) | CQ | 1.5 hp (1.12 kw) | C |
| 82 inch (2083 mm) | CR | 2 hp (1.5 kw) | D |
| 83 inch (2108 mm) | CS | 3 hp (2.24 kw) | E |
| 84 inch (2134 mm) | CT | 5 hp (3.73 kw) | F |
| 85 inch (2159 mm) | CU | 7.5 hp (5.59 kw) | G |
| 86 inch (2184 mm) | CV | 10 hp (7.5 kw) | H |
| 87 inch (2210 mm) | CW | 15 hp (11.19 kw) | J |
| 88 inch (2235 mm) | DA | 20 hp (14.91 kw) | K |
| 89 inch (2261 mm) | DB | Operating Instructions | |
| 90 inch (2286 mm) | DC | • English | C) 7ML1998-5JD01 |
| 91 inch (2311 mm) | DD | • German | C) 7ML1998-5JD31 |
| 92 inch (2337 mm) | DE | Note: The Operating Instructions should be ordered as a separate item on the order. | |
| 93 inch (2362 mm) | DF | This device is shipped with the Siemens Milltronics manual CD containing the complete Operating Instructions library. | |
| 94 inch (2388 mm) | DG | Accessories | |
| 95 inch (2413 mm) | DH | Controller: forward, reverse, e-stop, off/on | C) 7MH7723-1JY |
| 96 inch (2438 mm) | DJ | Note: Motor starter and voltage transformer required for use with controller, 120 V AC required for controller | |
| 97 inch (2464 mm) | DK | | |
| 98 inch (2489 mm) | DL | | |
| 99 inch (2515 mm) | DM | | |
| 100 inch (2540 mm) | DN | | |
| 101 inch (2565 mm) | DP | | |
| 102 inch (2591 mm) | DQ | | |
| 103 inch (2616 mm) | DR | | |
| 104 inch (2642 mm) | DS | | |
| 105 inch (2667 mm) | DT | | |

C) Subject to export regulations AL: N, ECCN: EAR99.

Belt Scales

Belt Scales Accessories





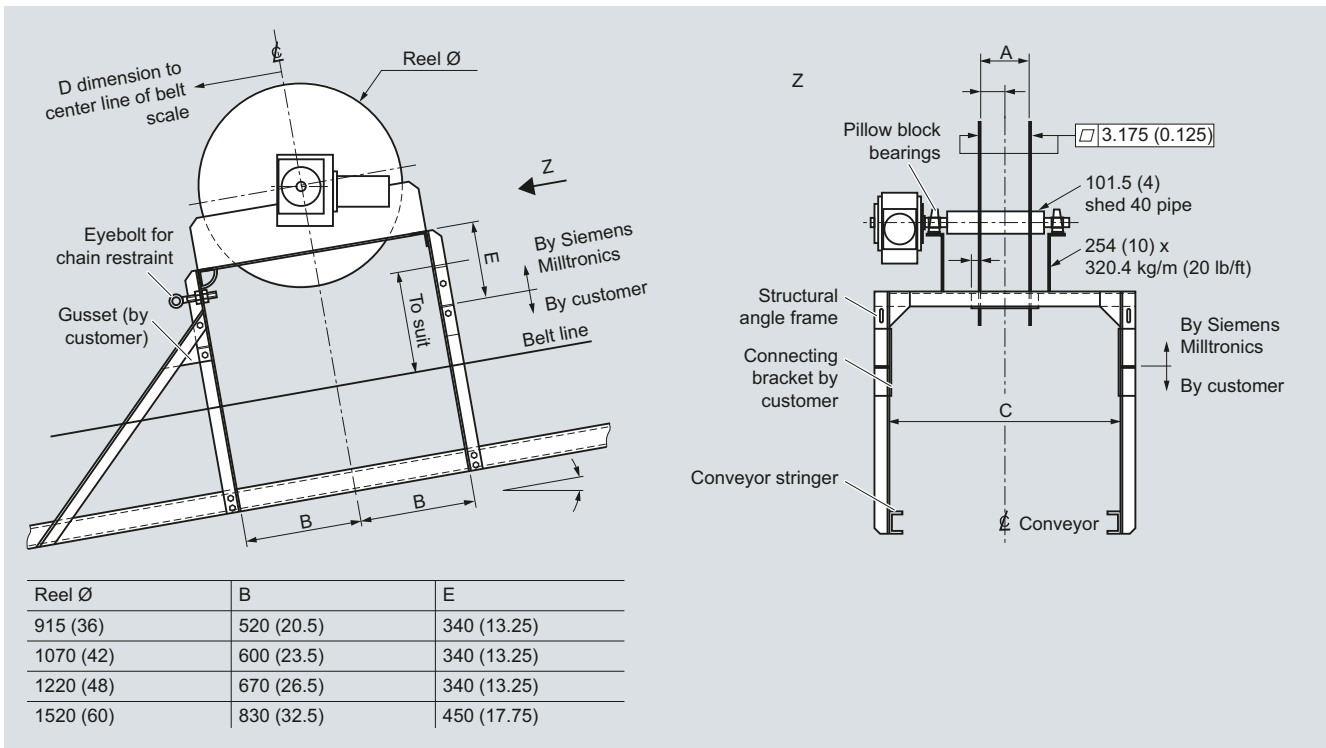

Milltronics Test Chain Storage Reels

Dimensional drawings



Milltronics test chain storage reel dimension in mm (inch)

Selection and Ordering data



| | | Order No. | | Order No. | |
|---|----|--------------------|---|--|-----------------------|
| Totalizer | | |  | | |
| 150 x 150 x 100D | C) | 7MH7723-1GG | | Belt scale connection cable, 6 cond, 20 G | C) 7MH7723-1JR |
| Nema 4 /IP65 enclosure | | | | (order per meter) | |
| Panel mount totalizer | C) | 7MH7726-1AU | | Note: for use with 1 or 2 load cell belt scales, for 4 or 6 load cell belt scales use 2 cables. This cable is intended for less than 150 m (500 ft) | |
| Ticket printers | | |  | Belt scale installation kit | C) 7MH7723-1KC |
| Ticket printer, TM-U295, 100 ... 240 V | | 7MH7726-1AK | | Note: comes with idler shims, alignment wire, and spacer blocks for idler alignment | |
| Printer cables | | | | Inclinometer | |
| Printer cables for TM-U295 and TMU220B, RS 232, DB25 ... open end | | 7MH7726-1AH | | Ceasco model IT9420 | C) 7MH7726-1AP |
| RS 485 ... RS 232 DB25 | C) | 7MH7726-1AJ | |  | |
| male converters for TMU295 and TMU220B printer | | | | Belt scale spare load cells | |
| Roll printer | | |  | For Milltronics Torque shaft belt scale (MTS), model CD or CFI, mounting hardware included | |
| Roll printer, TMU220B, 100 ... 240 V (required for German and Spanish printing) | C) | 7MH7726-1AT | | 50 lb (22.7 kg) | C) 7MH7725-1BA |
| Chart recorder | C) | 7MH7726-1AL |  | 75 lb (34 kg) | C) 7MH7725-1BB |
| Totalizer with Hi/Low alarm lights, 584 x 483 x 203D Nema 4 /IP65 enclosure | | | | 100 lb (45.4 kg) | C) 7MH7725-1BC |
| Terminal box load cell / speed sensor, 150 x 200 x 100 NEMA 4/IP65 enclosure | | |  | 150 lb (68 kg) | C) 7MH7725-1BD |
| Mild steel | C) | 7MH7723-1HS | | 300 lb (136.1 kg) | C) 7MH7725-1BE |
| Stainless steel | C) | 7MH7723-1HT | | 500 lb (226.8 kg) | C) 7MH7725-1BF |
| Mild steel, 4 load cells | C) | 7MH7723-1JW | | 750 lb (340.2 kg) | C) 7MH7725-1BG |
| Stainless steel, 4 load cells | C) | 7MH7723-1JX | | 1000 lb (453.6 kg) | C) 7MH7725-1BH |
| Note: for MMI-3 standard and 4 load cell, terminal boxes are required. | | | | 1500 lb (680.4 kg) | C) 7MH7725-1BJ |
| | | | | For MSI belt scale with round static beam, low-profile, mounting hardware included, model 60048-XXX-0137 or 60048-XXX-0129 | |
| | | | | 25 lb (11.3 kg) | C) 7MH7725-1AJ |
| | | | | 50 lb (22.7 kg) | C) 7MH7725-1AK |
| | | | | 100 lb (45.4 kg) | C) 7MH7725-1AL |
| | | | | 200 lb (90.7 kg) | C) 7MH7725-1AM |
| | | | | 400 lb (181.4 kg) | C) 7MH7725-1AN |
| | | | | 500 lb (226.8 kg) | C) 7MH7725-1AP |
| | | | | 1000 lb (453.6 kg) | C) 7MH7725-1AQ |
| | | | | For retrofitting current and older version of MSI with Group 4, mounting hardware included, sensortronics 60048-xxx-0138, or RTI, Model 6500 | |
| | | | | 50 lb (22.7 kg) | C) 7MH7725-1AC |
| | | | | 100 lb (45.4 kg) | C) 7MH7725-1AD |
| | | | | 250 lb (113.4 kg) | C) 7MH7725-1AE |
| | | | | 500 lb (226.8 kg) | C) 7MH7725-1AF |
| | | | | 750 lb (340.2 kg) | C) 7MH7725-1AG |
| | | | | 1000 lb (453.6 kg) | C) 7MH7725-1AH |



Belt Scales

Belt Scales Accessories

Milltronics Belt Scale Peripherals

Selection and Ordering data (continued)

| | Order No. | |
|---|---------------------------|---|
| <u>For retrofitting older version of MSI C462 (transducers incorporated), mounting hardware included</u> | |  |
| 50 lb (22.7 kg) | C) PBD-23900005 | |
| 100 lb (45.4 kg) | C) PBD-23900010 | |
| 250 lb (113.4 kg) | C) PBD-23900012 | |
| <u>For retrofitting older MMW & MCS belt scales that do not have a conduit adaptor, belt scale mounting hardware included</u> | |  |
| 50 lb | C) 7MH7725-1BN | |
| 100 lb | C) 7MH7725-1BP | |
| 250 lb | C) 7MH7725-1BQ | |
| <u>For retrofitting older MIC belt scale, mounting hardware included</u> | |  |
| 25 lb | Replace with 50 lb | |
| 50 lb (22.7 kg) | C) PBD-61009735 | |
| 100 lb (45.4 kg) | C) PBD-61009731 | |
| 250 lb (113.4 kg) | C) PBD-61009732 | |
| 500 lb (226.8 kg) | C) PBD-61009733 | |
| 1000 lb (453.6 kg) | C) PBD-61009734 | |
| 2000 lb (907.2 kg) | C) PBD-61009737 | |
| Kit, 2 idler cable suspension | PBD-61010081 | |
| Kit, 2 idler cable suspension, heavy duty | PBD-61010082 | |
| Kit, 4 idler cable suspension, heavy duty | PBD-61010742 | |
| Kit, 4 idler cable suspension, magnum | PBD-61010743 | |
| Kit, 4 idler cable suspension, standard | PBD-61010741 | |
| Right pivot assembly | PBD-20150020 | |
| Left pivot assembly | PBD-20150015 | |
| Bearing assembly | C) PBD-51010202 | |
| Shock washers | PBD-54000161 | |
| Bearing flange 1 3/16 | PBD-20250015 | |

| | Order No. | |
|---|------------------------|---|
| <u>For MUS HD aluminum model 7MH71202, mounting hardware included</u> | |  |
| 50 kg (110.2 lb) | C) 7MH7725-1BW | |
| 100 kg (220.4 lb) | C) 7MH7725-1BX | |
| 150 kg (330.7 lb) | C) 7MH7725-1BY | |
| 200 kg (440.9 lb) | C) 7MH7725-1CA | |
| 300 kg (661.4 lb) | C) 7MH7725-1CB | |
| 500 kg (1102.3 lb) | C) 7MH7725-1CC | |
| <u>For WD600 model 7MH7185</u> | |  |
| 25 lb (11.3 kg) | C) PBD-23900224 | |
| 50 lb (22.7 kg) | C) PBD-23900225 | |

C) Subject to export regulations AL: N, ECCN: EAR99.